



Cadi Company Inc.

**MANUFACTURER AND DISTRIBUTOR OF
HIGH CONDUCTIVITY COPPER ALLOYS
AND RESISTANCE WELDING PRODUCTS**



CAPS

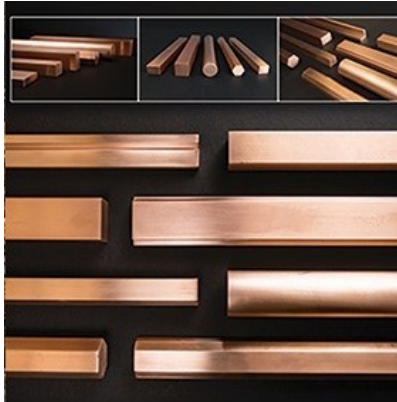

MESH WELDING ELECTRODES

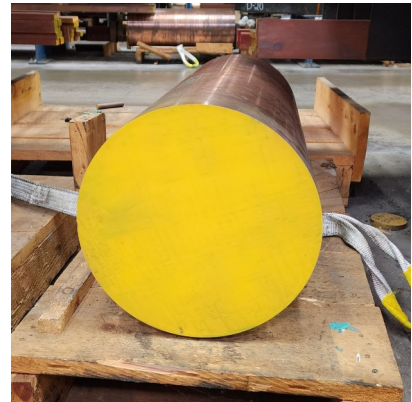

FORGED ROUND BAR



CHILL PLATE

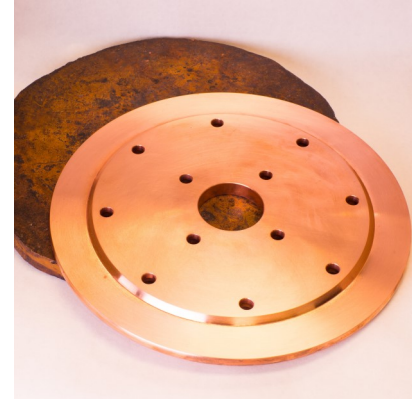

SEAM WELD WHEEL



VARIOUS ELECTRODES

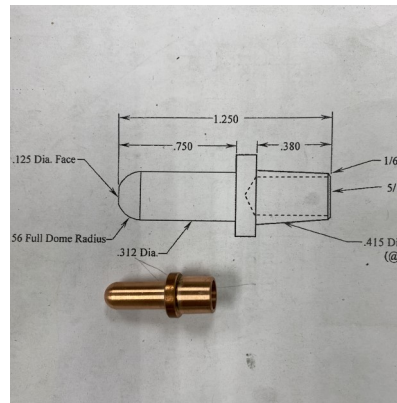

ELECTRODE

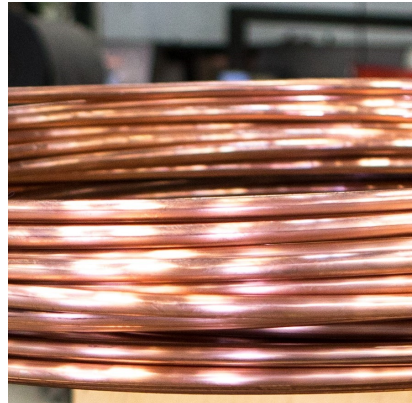

COIL



THREADED ROD



COPPER ALLOY PLATE



NUT WELD ELECTRODE



Cadi Company, Inc. P.O. Box 1127, 60 Rado Drive, Naugatuck, CT 06770
www.cadicompany.com 800-243-3650 203-729-1111



**Cadi
Company
Inc.**

**P. O. Box 1127
60 Rado Drive
Naugatuck, CT 06770**

**(800)243-3650
(203)729-1111**

**sales@cadicompany.com
www.cadicompany.com**



Cadi Company is an ISO certified manufacturer and distributor of high conductivity copper alloys. We specialize in copper that is used to manufacture resistance welding components such as welding wheels, electrodes and numerous other applications that demand performance beyond the capability of standard coppers. Copper alloys are in stock, ready to ship in rod, bar, plate, and special sizes.

This catalog is a sampling of our frequently manufactured consumables. If you don't find it, we have it or can make it.

**Cadi Company, Inc. P.O. Box 1127, 60 Rado Drive, Naugatuck, CT 06770
www.cadicompany.com 800-243-3650 203-729-1111**



TABLE OF CONTENTS

ELECTRODES, CAPS & SHANKS, SEAM WELD WHEELS	3-22	CYLINDER MOUNTED ACCESSORIES	23-25
STANDARD WELDING ELECTRODES	3-5	STRAIGHT HOLDERS AND CLAMPS	23
WELDING CAPS & SHANKS	6-7	OFFSET HOLDERS / INSULATION	24
OFFSET SHANKS FOR WELDING CAPS	8	WATER TUBES/ CADI COPPR-LUBE	25
METRIC ISO CAPS	9	AIR AND WATER COOLED CABLES & LAMINATED SHUNTS	26-29
REFRACTORY METAL-FACED ELECTRODES	10	WATER COOLED CABLES	26
BACKUP & SWIVEL ELECTRODES	11	AIR COOLED CABLES	27
DOUBLE BEND ELECTRODES	12	LAMINATED SHUNTS	28
IRREGULAR SHAPED ELECTRODES	13	LAMINATED SHUNT SELECTION FORM	29
30 DEGREE OFFSET NOSE ELECTRODES	13	WELD CONTROLS & WATER CHILLERS	30
SINGLE BEND ELECTRODES	14	COPPER ALLOY BAR STOCK	31
PADDLE HOLDERS AND SOCKET TIPS	15	REFRACTORY METALS	32
THREADED TIPS	15	PHYSICAL PROPERTIES AND CHEMICAL COMPOSITIONS OF GROUP A AND B ALLOYS	33-34
VARIABLE OFFSET HOLDERS, ADAPTERS, ELECTRODES	16	MATERIAL COMPATIBILITY	35
STUD & NUT WELDING ELECTRODES	17	RESISTANCE WELDING PRODUCTS	36-37
METRIC NUT WELDING ELECTRODES	18		
METRIC NUT WELDING HOLDERS/ STUD WELDING ELECTRODES	19		
SEAM WELD WHEELS & BLANKS	20		
WIRE MESH WELDING DIES	21		
ELECTRODE ADAPTERS	22		

STANDARD WELDING ELECTRODES



Cadi Company standard electrodes are manufactured to RWMA specifications. Cadi makes all sizes in RWMA Class 1, 2, 3, and other Copper Alloys. Special shapes and sizes are available upon request.

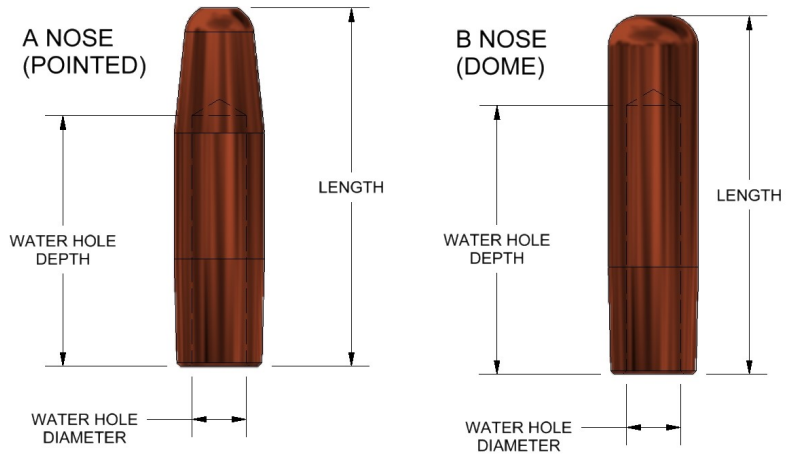

RWMA Class 1	RWMA Class 2	RWMA Class 3	Weld Face Diameter for A Nose	Length	Water Hole Depth	Water Hole Diameter	Weld Face Diameter for B Nose	RWMA Class 1	RWMA Class 2	RWMA Class 3
4RW Taper Nominal 1/2" Diameter							4RW Taper Nominal 1/2" Diameter			
CA-1404	CA-2404	CA-3404	3/16"	1"	1/2"	9/32"	3/16"	CB-1404	CB-2404	CB-3404
CA-1405	CA-2405	CA-3405	3/16"	1 1/4"	3/4"	9/32"	3/16"	CB-1405	CB-2405	CB-3405
CA-1406	CA-2406	CA-3406	3/16"	1 1/2"	1"	9/32"	3/16"	CB-1406	CB-2406	CB-3406
CA-1407	CA-2407	CA-3407	3/16"	1 3/4"	1 1/4"	9/32"	3/16"	CB-1407	CB-2407	CB-3407
CA-1408	CA-2408	CA-3408	3/16"	2"	1 1/2"	9/32"	3/16"	CB-1408	CB-2408	CB-3408
CA-1409	CA-2409	CA-3409	3/16"	2 1/4"	1 3/4"	9/32"	3/16"	CB-1409	CB-2409	CB-3409
CA-1410	CA-2410	CA-3410	3/16"	2 1/2"	2"	9/32"	3/16"	CB-1410	CB-2410	CB-3410
CA-1411	CA-2411	CA-3411	3/16"	2 3/4"	2 1/4"	9/32"	3/16"	CB-1411	CB-2411	CB-3411
CA-1412	CA-2412	CA-3412	3/16"	3"	2 1/2"	9/32"	3/16"	CB-1412	CB-2412	CB-3412
CA-1413	CA-2413	CA-3413	3/16"	3 1/4"	2 3/4"	9/32"	3/16"	CB-1413	CB-2413	CB-3413
CA-1414	CA-2414	CA-3414	3/16"	3 1/2"	3"	9/32"	3/16"	CB-1414	CB-2414	CB-3414
CA-1415	CA-2415	CA-3415	3/16"	3 3/4"	3 1/4"	9/32"	3/16"	CB-1415	CB-2415	CB-3415
CA-1416	CA-2416	CA-3416	3/16"	4"	3 1/2"	9/32"	3/16"	CB-1416	CB-2416	CB-3416
5RW Taper Nominal 5/8" Diameter							5RW Taper Nominal 5/8" Diameter			
CA-1505	CA-2505	CA-3505	1/4"	1 1/4"	1/2"	3/8"	1/4"	CB-1505	CB-2505	CB-3505
CA-1506	CA-2506	CA-3506	1/4"	1 1/2"	3/4"	3/8"	1/4"	CB-1506	CB-2506	CB-3506
CA-1507	CA-2507	CA-3507	1/4"	1 3/4"	1"	3/8"	1/4"	CB-1507	CB-2507	CB-3507
CA-1508	CA-2508	CA-3508	1/4"	2"	1 1/4"	3/8"	1/4"	CB-1508	CB-2508	CB-3508
CA-1509	CA-2509	CA-3509	1/4"	2 1/4"	1 1/2"	3/8"	1/4"	CB-1509	CB-2509	CB-3509
CA-1510	CA-2510	CA-3510	1/4"	2 1/2"	1 3/4"	3/8"	1/4"	CB-1510	CB-2510	CB-3510
CA-1511	CA-2511	CA-3511	1/4"	2 3/4"	2"	3/8"	1/4"	CB-1511	CB-2511	CB-3511
CA-1512	CA-2512	CA-3512	1/4"	3"	2 1/4"	3/8"	1/4"	CB-1512	CB-2512	CB-3512
CA-1513	CA-2513	CA-3513	1/4"	3 1/4"	2 1/2"	3/8"	1/4"	CB-1513	CB-2513	CB-3513
CA-1514	CA-2514	CA-3514	1/4"	3 1/2"	2 3/4"	3/8"	1/4"	CB-1514	CB-2514	CB-3514
CA-1515	CA-2515	CA-3515	1/4"	3 3/4"	3"	3/8"	1/4"	CB-1515	CB-2515	CB-3515
CA-1516	CA-2516	CA-3516	1/4"	4"	3 1/4"	3/8"	1/4"	CB-1516	CB-2516	CB-3516
6RW Taper Nominal 3/4" Diameter							6RW Taper Nominal 3/4" Diameter			
CA-1608	CA-2608	CA-3608	9/32"	2"	1 1/4"	7/16"	9/32"	CB-1608	CB-2608	CB-3608
CA-1610	CA-2610	CA-3610	9/32"	2 1/2"	1 3/4"	7/16"	9/32"	CB-1610	CB-2610	CB-3610
CA-1612	CA-2612	CA-3612	9/32"	3"	2 1/4"	7/16"	9/32"	CB-1612	CB-2612	CB-3612
CA-1614	CA-2614	CA-3614	9/32"	3 1/2"	2 3/4"	7/16"	9/32"	CB-1614	CB-2614	CB-3614
CA-1616	CA-2616	CA-3616	9/32"	4"	3 1/4"	7/16"	9/32"	CB-1616	CB-2616	CB-3616
7RW Taper Nominal 7/8" Diameter							7RW Taper Nominal 7/8" Diameter			
CA-1708	CA-2708	CA-3708	5/16"	2"	1 1/4"	1/2"	5/16"	CB-1708	CB-2708	CB-3708
CA-1710	CA-2710	CA-3710	5/16"	2 1/2"	1 3/4"	1/2"	5/16"	CB-1710	CB-2710	CB-3710
CA-1712	CA-2712	CA-3712	5/16"	3"	2 1/4"	1/2"	5/16"	CB-1712	CB-2712	CB-3712
CA-1714	CA-2714	CA-3714	5/16"	3 1/2"	2 3/4"	1/2"	5/16"	CB-1714	CB-2714	CB-3714
CA-1716	CA-2716	CA-3716	5/16"	4"	3 1/4"	1/2"	5/16"	CB-1716	CB-2716	CB-3716

STANDARD WELDING ELECTRODES

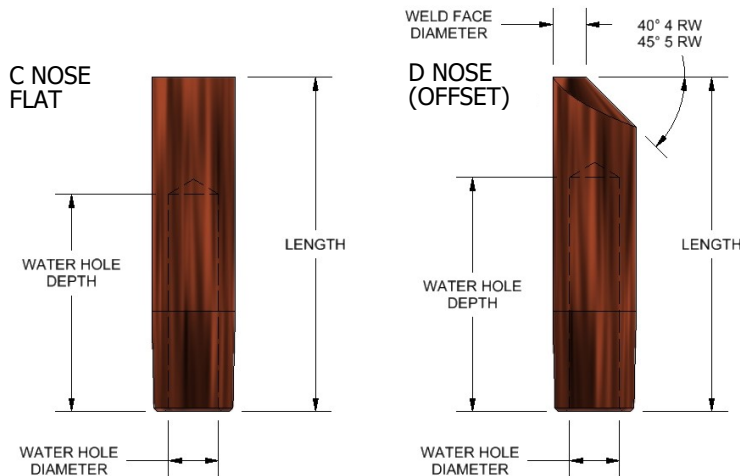

Cadi Company standard electrodes are manufactured to RWMA specifications. Cadi makes all sizes in RWMA Class 1, 2, and 3, and other Copper Alloys. Special shapes and sizes are available upon request.

RWMA Class 1	RWMA Class 2	RWMA Class 3	Weld Face Diameter for C Nose	Length	Water Hole Depth	Water Hole Diameter	Weld Face Diameter for D Nose	RWMA Class 1	RWMA Class 2	RWMA Class 3
4RW Taper Nominal 1/2" Diameter										
CC-1404	CC-2404	CC-3404	.482"	1"	1/2"	9/32"	3/16"	CD-1404	CD-2404	CD-3404
CC-1405	CC-2405	CC-3405	.482"	1 1/4"	3/4"	9/32"	3/16"	CD-1405	CD-2405	CD-3405
CC-1406	CC-2406	CC-3406	.482"	1 1/2"	1"	9/32"	3/16"	CD-1406	CD-2406	CD-3406
CC-1407	CC-2407	CC-3407	.482"	1 3/4"	1 1/4"	9/32"	3/16"	CD-1407	CD-2407	CD-3407
CC-1408	CC-2408	CC-3408	.482"	2"	1 1/2"	9/32"	3/16"	CD-1408	CD-2408	CD-3408
CC-1409	CC-2409	CC-3409	.482"	2 1/4"	1 3/4"	9/32"	3/16"	CD-1409	CD-2409	CD-3409
CC-1410	CC-2410	CC-3410	.482"	2 1/2"	2"	9/32"	3/16"	CD-1410	CD-2410	CD-3410
CC-1411	CC-2411	CC-3411	.482"	2 3/4"	2 1/4"	9/32"	3/16"	CD-1411	CD-2411	CD-3411
CC-1412	CC-2412	CC-3412	.482"	3"	2 1/2"	9/32"	3/16"	CD-1412	CD-2412	CD-3412
CC-1413	CC-2413	CC-3413	.482"	3 1/4"	2 3/4"	9/32"	3/16"	CD-1413	CD-2413	CD-3413
CC-1414	CC-2414	CC-3414	.482"	3 1/2"	3"	9/32"	3/16"	CD-1414	CD-2414	CD-3414
CC-1415	CC-2415	CC-3415	.482"	3 3/4"	3 1/4"	9/32"	3/16"	CD-1415	CD-2415	CD-3415
CC-1416	CC-2416	CC-3416	.482"	4"	3 1/2"	9/32"	3/16"	CD-1416	CD-2416	CD-3416
5RW Taper Nominal 5/8" Diameter										
CC-1505	CC-2505	CC-3505	5/8"	1 1/4"	1/2"	3/8"	1/4"	CD-1505	CD-2505	CD-3505
CC-1506	CC-2506	CC-3506	5/8"	1 1/2"	3/4"	3/8"	1/4"	CD-1506	CD-2506	CD-3506
CC-1507	CC-2507	CC-3507	5/8"	1 3/4"	1"	3/8"	1/4"	CD-1507	CD-2507	CD-3507
CC-1508	CC-2508	CC-3508	5/8"	2"	1 1/4"	3/8"	1/4"	CD-1508	CD-2508	CD-3508
CC-1509	CC-2509	CC-3509	5/8"	2 1/4"	1 1/2"	3/8"	1/4"	CD-1509	CD-2509	CD-3509
CC-1510	CC-2510	CC-3510	5/8"	2 1/2"	1 3/4"	3/8"	1/4"	CD-1510	CD-2510	CD-3510
CC-1511	CC-2511	CC-3511	5/8"	2 3/4"	2"	3/8"	1/4"	CD-1511	CD-2511	CD-3511
CC-1512	CC-2512	CC-3512	5/8"	3"	2 1/4"	3/8"	1/4"	CD-1512	CD-2512	CD-3512
CC-1513	CC-2513	CC-3513	5/8"	3 1/4"	2 1/2"	3/8"	1/4"	CD-1513	CD-2513	CD-3513
CC-1514	CC-2514	CC-3514	5/8"	3 1/2"	2 3/4"	3/8"	1/4"	CD-1514	CD-2514	CD-3514
CC-1515	CC-2515	CC-3515	5/8"	3 3/4"	3"	3/8"	1/4"	CD-1515	CD-2515	CD-3515
CC-1516	CC-2516	CC-3516	5/8"	4"	3 1/4"	3/8"	1/4"	CD-1516	CD-2516	CD-3516
6RW Taper Nominal 3/4" Diameter										
CC-1608	CC-2608	CC-3608	3/4"	2"	1 1/4"	7/16"	9/32"	CD-1608	CD-2608	CD-3608
CC-1610	CC-2610	CC-3610	3/4"	2 1/2"	1 3/4"	7/16"	9/32"	CD-1610	CD-2610	CD-3610
CC-1612	CC-2612	CC-3612	3/4"	3"	2 1/4"	7/16"	9/32"	CD-1612	CD-2612	CD-3612
CC-1614	CC-2614	CC-3614	3/4"	3 1/2"	2 3/4"	7/16"	9/32"	CD-1614	CD-2614	CD-3614
CC-1616	CC-2616	CC-3616	3/4"	4"	3 1/4"	7/16"	9/32"	CD-1616	CD-2616	CD-3616
7RW Taper Nominal 7/8" Diameter										
CC-1708	CC-2708	CC-3708	7/8"	2"	1 1/4"	1/2"	5/16"	CD-1708	CD-2708	CD-3708
CC-1710	CC-2710	CC-3710	7/8"	2 1/2"	1 3/4"	1/2"	5/16"	CD-1710	CD-2710	CD-3710
CC-1712	CC-2712	CC-3712	7/8"	3"	2 1/4"	1/2"	5/16"	CD-1712	CD-2712	CD-3712
CC-1714	CC-2714	CC-3714	7/8"	3 1/2"	2 3/4"	1/2"	5/16"	CD-1714	CD-2714	CD-3714
CC-1716	CC-2716	CC-3716	7/8"	4"	3 1/4"	1/2"	5/16"	CD-1716	CD-2716	CD-3716

STANDARD WELDING ELECTRODES



Cadi Company standard electrodes are manufactured to RWMA specifications. Cadi makes all sizes in RWMA Class 1, 2, and 3, and other Copper Alloys. Special shapes and sizes are available upon request.

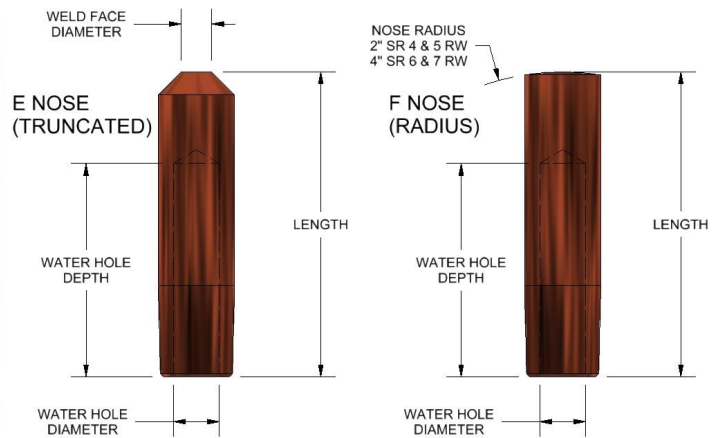

RWMA Class 1	RWMA Class 2	RWMA Class 3	Weld Face Diameter for E Nose	Length	Water Hole Depth	Water Hole Diameter	Nose Radius for F Nose	RWMA Class 1	RWMA Class 2	RWMA Class 3
4RW Taper Nominal 1/2" Diameter										
CE-1404	CE-2404	CE-3404	3/16"	1"	1/2"	9/32"	2"	CF-1404	CF-2404	CF-3404
CE-1405	CE-2405	CE-3405	3/16"	1 1/4"	3/4"	9/32"	2"	CF-1405	CF-2405	CF-3405
CE-1406	CE-2406	CE-3406	3/16"	1 1/2"	1"	9/32"	2"	CF-1406	CF-2406	CF-3406
CE-1407	CE-2407	CE-3407	3/16"	1 3/4"	1 1/4"	9/32"	2"	CF-1407	CF-2407	CF-3407
CE-1408	CE-2408	CE-3408	3/16"	2"	1 1/2"	9/32"	2"	CF-1408	CF-2408	CF-3408
CE-1409	CE-2409	CE-3409	3/16"	2 1/4"	1 3/4"	9/32"	2"	CF-1409	CF-2409	CF-3409
CE-1410	CE-2410	CE-3410	3/16"	2 1/2"	2"	9/32"	2"	CF-1410	CF-2410	CF-3410
CE-1411	CE-2411	CE-3411	3/16"	2 3/4"	2 1/4"	9/32"	2"	CF-1411	CF-2411	CF-3411
CE-1412	CE-2412	CE-3412	3/16"	3"	2 1/2"	9/32"	2"	CF-1412	CF-2412	CF-3412
CE-1413	CE-2413	CE-3413	3/16"	3 1/4"	2 3/4"	9/32"	2"	CF-1413	CF-2413	CF-3413
CE-1414	CE-2414	CE-3414	3/16"	3 1/2"	3"	9/32"	2"	CF-1414	CF-2414	CF-3414
CE-1415	CE-2415	CE-3415	3/16"	3 3/4"	3 1/4"	9/32"	2"	CF-1415	CF-2415	CF-3415
CE-1416	CE-2416	CE-3416	3/16"	4"	3 1/2"	9/32"	2"	CF-1416	CF-2416	CF-3416
5RW Taper Nominal 5/8" Diameter										
CE-1505	CE-2505	CE-3505	1/4"	1 1/4"	1/2"	3/8"	2"	CF-1505	CF-2505	CF-3505
CE-1506	CE-2506	CE-3506	1/4"	1 1/2"	3/4"	3/8"	2"	CF-1506	CF-2506	CF-3506
CE-1507	CE-2507	CE-3507	1/4"	1 3/4"	1"	3/8"	2"	CF-1507	CF-2507	CF-3507
CE-1508	CE-2508	CE-3508	1/4"	2"	1 1/4"	3/8"	2"	CF-1508	CF-2508	CF-3508
CE-1509	CE-2509	CE-3509	1/4"	2 1/4"	1 1/2"	3/8"	2"	CF-1509	CF-2509	CF-3509
CE-1510	CE-2510	CE-3510	1/4"	2 1/2"	1 3/4"	3/8"	2"	CF-1510	CF-2510	CF-3510
CE-1511	CE-2511	CE-3511	1/4"	2 3/4"	2"	3/8"	2"	CF-1511	CF-2511	CF-3511
CE-1512	CE-2512	CE-3512	1/4"	3"	2 1/4"	3/8"	2"	CF-1512	CF-2512	CF-3512
CE-1513	CE-2513	CE-3513	1/4"	3 1/4"	2 1/2"	3/8"	2"	CF-1513	CF-2513	CF-3513
CE-1514	CE-2514	CE-3514	1/4"	3 1/2"	2 3/4"	3/8"	2"	CF-1514	CF-2514	CF-3514
CE-1515	CE-2515	CE-3515	1/4"	3 3/4"	3"	3/8"	2"	CF-1515	CF-2515	CF-3515
CE-1516	CE-2516	CE-3516	1/4"	4"	3 1/4"	3/8"	2"	CF-1516	CF-2516	CF-3516
6RW Taper Nominal 3/4" Diameter										
CE-1608	CE-2608	CE-3608	9/32"	2"	1 1/4"	7/16"	4"	CF-1608	CF-2608	CF-3608
CE-1610	CE-2610	CE-3610	9/32"	2 1/2"	1 3/4"	7/16"	4"	CF-1610	CF-2610	CF-3610
CE-1612	CE-2612	CE-3612	9/32"	3"	2 1/4"	7/16"	4"	CF-1612	CF-2612	CF-3612
CE-1614	CE-2614	CE-3614	9/32"	3 1/2"	2 3/4"	7/16"	4"	CF-1614	CF-2614	CF-3614
CE-1616	CE-2616	CE-3616	9/32"	4"	3 1/4"	7/16"	4"	CF-1616	CF-2616	CF-3616
7RW Taper Nominal 7/8" Diameter										
CE-1708	CE-2708	CE-3708	5/16"	2"	1 1/4"	1/2"	4"	CF-1708	CF-2708	CF-3708
CE-1710	CE-2710	CE-3710	5/16"	2 1/2"	1 3/4"	1/2"	4"	CF-1710	CF-2710	CF-3710
CE-1712	CE-2712	CE-3712	5/16"	3"	2 1/4"	1/2"	4"	CF-1712	CF-2712	CF-3712
CE-1714	CE-2714	CE-3714	5/16"	3 1/2"	2 3/4"	1/2"	4"	CF-1714	CF-2714	CF-3714
CE-1716	CE-2716	CE-3716	5/16"	4"	3 1/4"	1/2"	4"	CF-1716	CF-2716	CF-3716

MALE WELDING CAPS AND SHANKS

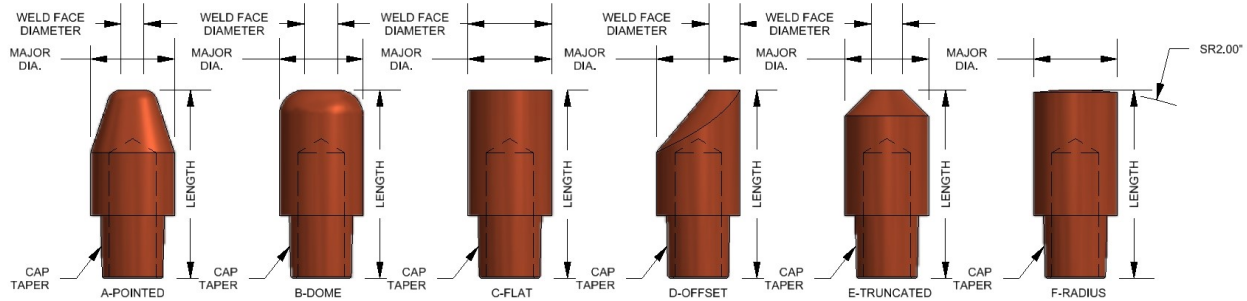

CLASS 1	CLASS 2	CLASS 3	NOSE TYPE	MAJOR DIAMETER	WELD FACE DIAMETER	LENGTH
CA-14	CA-24	CA-34	A	0.482"	3/16"	1-1/8"
CB-14	CB-24	CB-34	B	0.482"	3/16"	1-1/8"
CC-14	CC-24	CC-34	C	0.482"	.482"	1-1/8"
CD-14	CD-24	CD-34	D	0.482"	3/16"	1-1/8"
CE-14	CE-24	CE-34	E	0.482"	3/16"	1-1/8"
CF-14	CF-24	CF-34	F	0.482"	SR2.00"	1-1/8"
CA-15	CA-25	CA-35	A	0.625"	1/4"	1-1/4"
CB-15	CB-25	CB-35	B	0.625"	1/4"	1-1/4"
CC-15	CC-25	CC-35	C	0.625"	5/8"	1-1/4"
CD-15	CD-25	CD-35	D	0.625"	1/4"	1-1/4"
CE-15	CE-25	CE-35	E	0.625"	1/4"	1-1/4"
CF-15	CF-25	CF-35	F	0.625"	SR2.00"	1-1/4"

STRAIGHT SHANKS FOR MALE CAPS

4 RW CAP TAPER	MAJOR DIAMETER	LENGTH	ASSEMBLED LENGTH
CG-2405	0.482"	1-1/4"	2"
CG-2406	0.482"	1-1/2"	2-1/4"
CG-2407	0.482"	1-3/4"	2-1/2"
CG-2408	0.482"	2"	2-3/4"
CG-2409	0.482"	2-1/4"	3"
CG-2410	0.482"	2-1/2"	3-1/4"
CG-2411	0.482"	2-3/4"	3-1/2"
CG-2412	0.482"	3"	3-3/4"
CG-2413	0.482"	3-1/4"	4"
CG-2414	0.482"	3-1/2"	4-1/4"
CG-2415	0.482"	3-3/4"	4-1,2"
CG-2416	0.482"	4"	4-3/4"

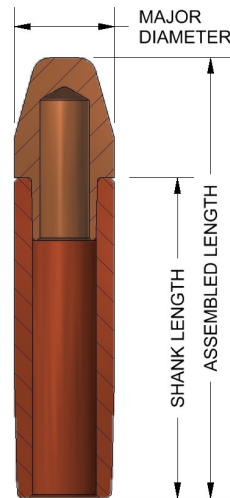

Cadi offers male caps and straight or bent shanks in 4, 5, 6 and 7 RW tapers (6 & 7 not shown).

5 RW CAP TAPER	MAJOR DIAMETER	LENGTH	ASSEMBLED LENGTH
CG-2505	0.625"	1-1/4"	2"
CG-2506	0.625"	1-1/2"	2-1/4"
CG-2507	0.625"	1-3/4"	2-1/2"
CG-2508	0.625"	2"	2-3/4"
CG-2509	0.625"	2-1/4"	3"
CG-2510	0.625"	2-1/2"	3-1/4"
CG-2511	0.625"	2-3/4"	3-1/2"
CG-2512	0.625"	3"	3-3/4"
CG-2513	0.625"	3-1/4"	4"
CG-2514	0.625"	3-1/2"	4-1/4"
CG-2515	0.625"	3-3/4"	4-1/2"

Cadi Company manufactures standard and to-print male and female RWMA and ISO welding caps and shanks. Caps and shanks are a two part alternative to straight electrodes in which the shank can be reused many times. Please specify if shanks are being used with ISO caps. The taper is different from RWMA standard.

Resistance welding cap technology gives the end user an economical, efficient alternative to standard electrodes. Their small size and ease of maintenance makes them ideal alternatives in high duty cycle applications. Standard nose configurations, special shapes and sizes are available in RWMA Class 1, 2, 3 and other Copper Alloys.

FEMALE WELDING CAPS AND SHANKS

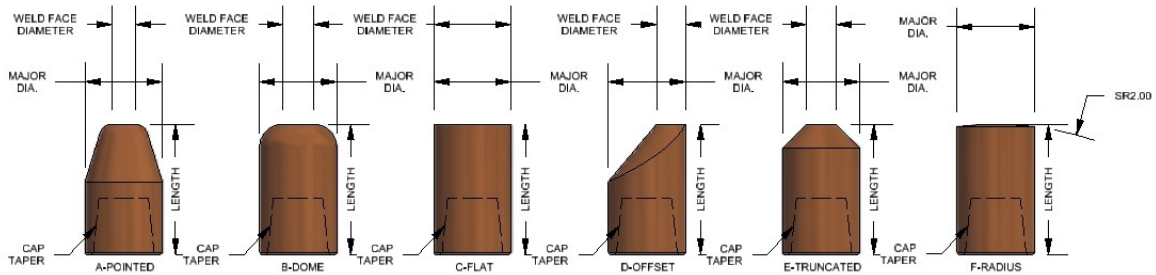

CLASS 1	CLASS 2	CLASS 3	NOSE TYPE	MAJOR DIAMETER	WELD FACE DIAMETER	LENGTH
CFA-14	CFA-24	CFA-34	A	0.482"	3/16"	.84"
CFB-14	CFB-24	CFB-34	B	0.482"	3/16"	.84"
CFC-14	CFC-24	CFC-34	C	0.482"	0.482"	.84"
CFD-14	CFD-24	CFD-34	D	0.482"	3/16"	.84"
CFE-14	CFE-24	CFE-34	E	0.482"	3/16"	.84"
CFF-14	CFF-24	CFF-34	F	0.482"	SR2.00"	.84"
CFA-15	CFA-25	CFA-35	A	0.625"	3/16" or 1/4"	.88"
CFB-15	CFB-25	CFB-35	B	0.625"	3/16" or 1/4"	.88"
CFC-15	CFC-25	CFC-35	C	0.625"	5/8"	.88"
CFD-15	CFD-25	CFD-35	D	0.625"	3/16" or 1/4"	.88"
CFE-15	CFE-25	CFE-35	E	0.625"	3/16" or 1/4"	.88"
CFF-15	CFF-25	CFF-35	F	0.625"	SR2.00"	.88"

STRAIGHT SHANKS FOR FEMALE CAPS

4 RW CAP TAPER	MAJOR DIAMETER	SHANK LENGTH	ASSEMBLED LENGTH
CFG-2405	0.482"	1-1/4"	1.85"
CFG-2406	0.482"	1-1/2"	2.10"
CFG-2407	0.482"	1-3/4"	2.35"
CFG-2408	0.482"	2"	2.60"
CFG-2409	0.482"	2-1/4"	2.85"
CFG-2410	0.482"	2-1/2"	3.10"
CFG-2411	0.482"	2-3/4"	3.35"
CFG-2412	0.482"	3"	3.60"
CFG-2413	0.482"	3-1/4"	3.85"
CFG-2414	0.482"	3-1/2"	4.10"
CFG-2415	0.482"	3-3/4"	4.35"
CFG-2416	0.482"	4"	4.60"

5 RW CAP TAPER	MAJOR DIAMETER	SHANK LENGTH	ASSEMBLED LENGTH
CFG-2505	0.625"	1-1/4"	1.89"
CFG-2506	0.625"	1-1/2"	2.14"
CFG-2507	0.625"	1-3/4"	2.39"
CFG-2508	0.625"	2"	2.64"
CFG-2509	0.625"	2-1/4"	2.89"
CFG-2510	0.625"	2-1/2"	3.14"
CFG-2511	0.625"	2-3/4"	3.39"
CFG-2512	0.625"	3"	3.64"
CFG-2513	0.625"	3-1/4"	3.89"
CFG-2514	0.625"	3-1/2"	4.14"
CFG-2415	0.625"	3-3/4"	4.39"
CFG-2416	0.625"	4"	4.64"

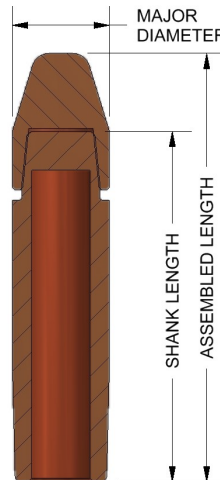

Cadi offers female caps and straight or bent shanks in 4, 5, 6 and 7 RW tapers (6 & 7 not shown).

Cadi Company manufactures standard and to-print male and female RWMA and ISO welding caps and shanks. Please specify if shanks are being used with ISO caps. The taper is different from RWMA standard. Caps and shanks are a two part alternative to straight electrodes in which the shank can be reused many times. Female shanks may be ordered with, or without a thru hole. Add a "-T" to the part number to specify a thru hole.

Resistance welding cap technology gives the end user an economical, efficient alternative to standard electrodes. Their small size and ease of maintenance makes them ideal alternatives in high duty cycle applications. All standard nose configurations are available. Special shapes and sizes are available in RWMA Class 1, 2, 3, and other Copper Alloys.

OFFSET SHANKS FOR MALE AND FEMALE CAPS

OFFSET SHANKS FOR MALE CAPS

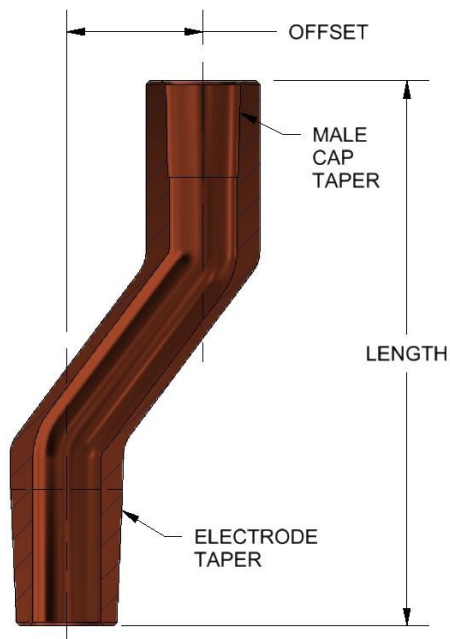

PART NUMBER	OFFSET	LENGTH	ASSEMBLED LENGTH
CG-2410-08	1/2"	2-1/2"	3-1/4"
CG-2410-12	3/4"	2-1/2"	3-1/4"
CG-2410-16	1"	2-1/2"	3-1/4"
CG-2412-08	1/2"	3"	3-3/4"
CG-2412-20	1-1/4"	3"	3-3/4"
CG-2413-16	1"	3-1/4"	4"

CG-2510-08	1/2"	2-1/2"	3-1/4"
CG-2510-12	3/4"	2-1/2"	3-1/4"
CG-2510-16	1"	2-1/2"	3-1/4"
CG-2512-8	1/2"	3"	3-3/4"
CG-2512-12	3/4"	3"	3-3/4"
CG-2513-16	1"	3-1/4"	4"

Items listed are several of the most popular sizes. Other lengths and offsets are available.

Shanks for female caps may be ordered with or without a thru hole. Please add a "-T" for shanks with a thru hole.

Please specify if shanks are to be used with Metric ISO caps. The taper is different.

OFFSET SHANKS FOR FEMALE CAPS

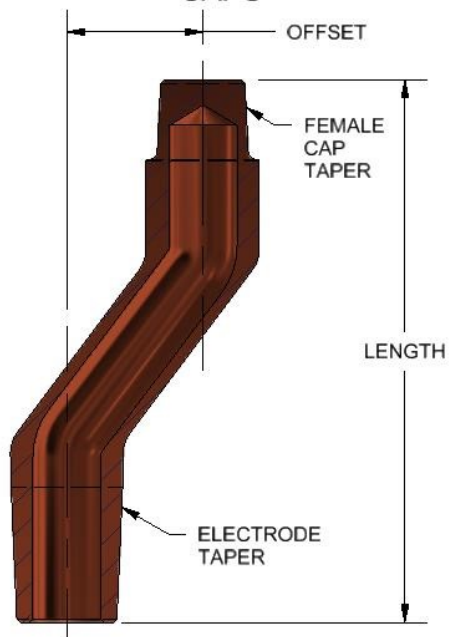

PART NUMBER	OFFSET	LENGTH	ASSEMBLED LENGTH
CFG-2411-08	1/2"	2-3/4"	3-1/4"
CFG-2411-12	3/4"	2-3/4"	3-1/4"
CFG-2411-16	1"	2-3/4"	3-1/4"
CFG-2413-08	1/2"	3-1/4"	3-3/4"
CFG-2413-20	1-1/4"	3-1/4"	3-3/4"
CFG-2414-16	1"	3-1/2"	4"

CFG-2511-08	1/2"	2-3/4"	3-1/4"
CFG-2511-12	3/4"	2-3/4"	3-1/4"
CFG-2511-16	1"	2-3/4"	3-1/4"
CFG-2513-08	1/2"	3-1/4"	3-3/4"
CFG-2513-12	3/4"	3-1/4"	3-3/4"
CFG-2514-16	1"	3-1/2"	4"

Cadi shanks are made with RWMA Class 2 copper. Class 1 or Class 3 are available as an option.

METRIC ISO CAPS

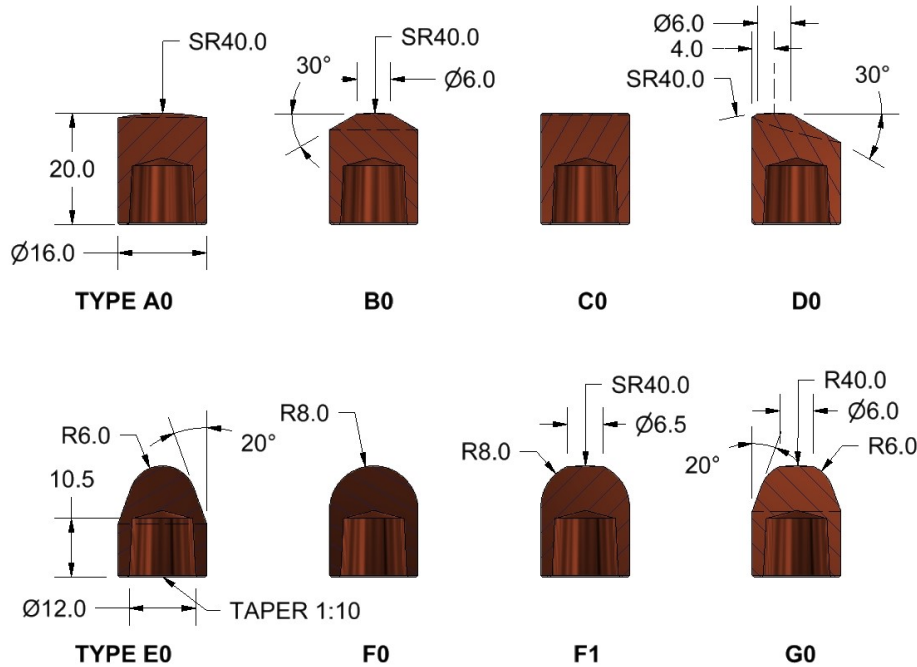

Cadi produces a wide variety of Metric ISO electrode caps. Standard 16 mm diameter caps are shown above. ISO caps are available in 13, 16, and 20 mm diameters. Preferred lengths are 18, 20 and 22 mm respectively. Weld face diameters are 5, 6, and 8 mm respectively. Dimensions may vary slightly for 13 and 20 mm diameter caps. In the standard configuration, these caps have a 1:10 taper.

Cadi's ISO caps adhere to the ISO 5821 International Standard.

ISO caps are available in the same alloys as our RWMA caps.

The same shanks that are available for RWMA caps are also available for ISO caps. Please specify that ISO caps are being used when ordering shanks. The tapers are different.

We can also make caps with the ISO taper to your custom design. Contact your Cadi representative for more information on custom caps.

TYPE	DIAMETER	LENGTH	WELD FACE	WELD FACE RADIUS	TAPER MAJOR DIAMETER
A0	13/16/20	18/20/22		30/40/50	10/12/15
B0	13/16/20	18/20/22	5/6/8	30/40/50	10/12/15
C0	13/16/20	18/20/22			10/12/15
D0	13/16/20	18/20/22	5/6/8	32/40/50	10/12/15
E0	13/16/20	18/20/22		5/6/8	10/12/15
F0	13/16/20	18/20/22		6.5/8/10	10/12/15
F1	13/16/20	18/20/22	5/6/8	50/50/50	10/12/15
G0	13/16/20	18/20/22	5/6/8	32/40/50	10/12/15

REFRACTORY METAL-FACED ELECTRODES

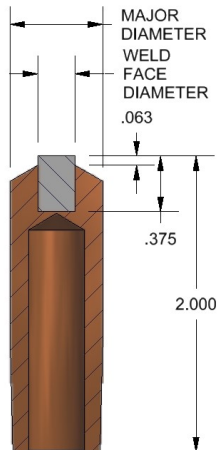

4 RW TAPER	NOSE TYPE	MAJOR DIAMETER	WELD FACE DIAMETER	LENGTH	INSERT MATERIAL
FC10 408	A	0.482"	3/16"	2"	COPPER TUNGSTEN (10W)
FCM 408	A	0.482"	3/16"	2"	MOLYBDENUM (100M)
FCT 408	A	0.482"	3/16"	2"	TUNGSTEN (100W)

5 RW TAPER	NOSE TYPE	MAJOR DIAMETER	WELD FACE DIAMETER	LENGTH	INSERT MATERIAL
FC10 508	A	0.625"	1/4"	2"	COPPER TUNGSTEN (10W)
FCM 508	A	0.625"	1/4"	2"	MOLYBDENUM (100M)
FCT 508	A	0.625"	1/4"	2"	TUNGSTEN (100W)

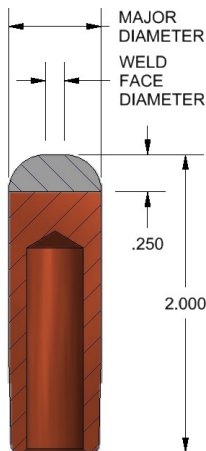

4 RW TAPER	NOSE TYPE	MAJOR DIAMETER	WELD FACE DIAMETER	LENGTH	INSERT MATERIAL
FD10 408	B	0.482"	1/8"	2"	COPPER TUNGSTEN (10W)
FDM 408	B	0.482"	1/8"	2"	MOLYBDENUM (100M)
FDT 408	B	0.482"	1/8"	2"	TUNGSTEN (100W)

5 RW TAPER	NOSE TYPE	MAJOR DIAMETER	WELD FACE DIAMETER	LENGTH	INSERT MATERIAL
FD10 508	B	0.625"	1/8"	2"	COPPER TUNGSTEN (10W)
FDM 508	B	0.625"	1/8"	2"	MOLYBDENUM (100M)
FDT 508	B	0.625"	1/8"	2"	TUNGSTEN (100W)

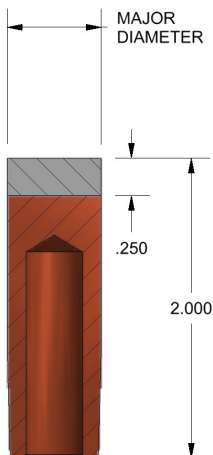

4 RW TAPER	NOSE TYPE	MAJOR DIAMETER	WELD FACE DIAMETER	LENGTH	INSERT MATERIAL
FF10 408	C	0.482"	.482"	2"	COPPER TUNGSTEN (10W)
FFM 408	C	0.482"	.482"	2"	MOLYBDENUM (100M)
FFT 408	C	0.482"	.482"	2"	TUNGSTEN (100W)

5 RW TAPER	NOSE TYPE	MAJOR DIAMETER	WELD FACE DIAMETER	LENGTH	INSERT MATERIAL
FF10 508	C	0.625"	5/8"	2"	COPPER TUNGSTEN (10W)
FFM 508	C	0.625"	5/8"	2"	MOLYBDENUM (100M)
FFT 508	C	0.625"	5/8"	2"	TUNGSTEN (100W)

Cadi Company manufactures standard and to-print refractory metal-faced electrodes that can be used in high heat, high force applications, and heat balancing to improve nugget size or location. RWMA Class 2 copper is used for the electrode body. Special shapes and sizes are available upon request.

BACKUP AND SWIVEL ELECTRODES

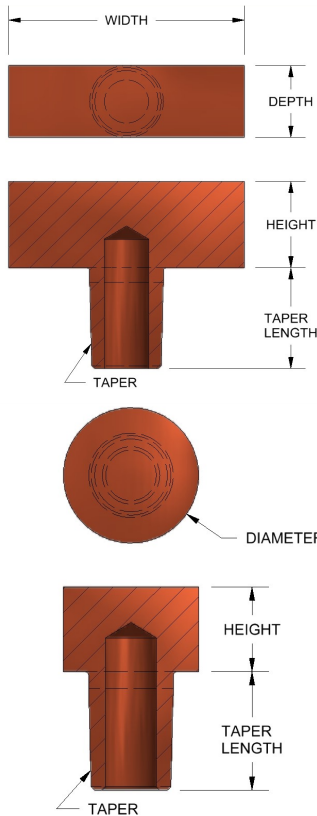

RECTANGULAR BACKUP ELECTRODES					
PART NUMBER	RW TAPER	WIDTH	DEPTH	HEIGHT	TAPER LENGTH
C-237	4RW	1/2"	1/2"	11/16"	13/16"
C-109	5RW	5/8"	5/8"	7/8"	7/8"
C-382	4RW	1"	1/2"	3/4"	7/8"
C-383	5RW	1"	1/2"	3/4"	7/8"
C-384	4RW	1-1/2"	5/8"	3/4"	7/8"
C-385	5RW	1-1/2"	5/8"	3/4"	7/8"
C-127	4RW	2"	5/8"	3/4"	7/8"
C-125	5RW	2"	5/8"	3/4"	7/8"

ROUND BACKUP ELECTRODES				
PART NUMBER	RW TAPER	DIAMETER	HEIGHT	TAPER LENGTH
C-375	4RW	7/8"	5/8"	7/8"
C-378	5RW	7/8"	5/8"	7/8"
C-161	4RW	1"	5/8"	7/8"
C-183	5RW	1"	5/8"	7/8"
C-376	4RW	1-1/4"	5/8"	5/8"
C-379	5RW	1-1/4"	5/8"	7/8"
C-377	4RW	1-1/2"	5/8"	7/8"
C-380	5RW	1-1/2"	5/8"	7/8"

Cadi Company manufactures standard and to-print backup electrodes in round, square, and rectangular shapes. Electrodes are available in RWMA Class 1, 2, or 3 and can be faced with copper-tungsten, molybdenum, tungsten and other refractory metals. The standard material for backup electrodes is RWMA Class 2. Special shapes, sizes, and materials are available upon request.

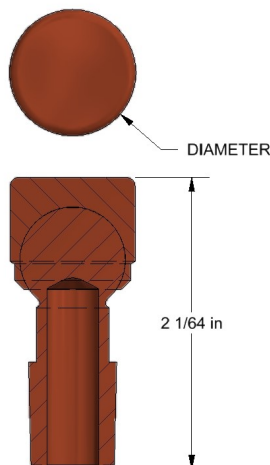

SWIVEL HEAD ELECTRODES				
PART NUMBER	RW TAPER	DIAMETER	HEIGHT	TYPE
C-369	4RW	7/8"	2-1/64"	BLIND HOLE
C-370	5RW	7/8"	2-1/64"	BLIND HOLE
C-216	4RW	1"	2-1/64"	BLIND HOLE
C-120	5RW	1"	2-1-64"	BLIND HOLE
C-204	4RW	1-1/4"	2-1/64"	BLIND HOLE
C-217	5RW	1-1/4"	2-1/64"	BLIND HOLE
C-348	4 RW	1"	2-1/64"	BALL & SPRING
C-350	5 RW	1"	2-1/64"	BALL & SPRING
C-349	4 RW	1-1/4"	2-1/64"	BALL & SPRING
C-351	5 RW	1-1/4"	2-1/64"	BALL & SPRING
C-373	4 RW	7/8"	2-1/64"	THRU HOLE
C-328	5 RW	7/8"	2-1/64"	THRU HOLE
C-352	4 RW	1"	2-1/64"	THRU HOLE
C-354	5 RW	1"	2-1/64"	THRU HOLE
C-353	4 RW	1-1/4"	2-1/64"	THRU HOLE
C-355	5 RW	1-1/4"	2-1/64"	THRU HOLE

Many other diameters and lengths available.

Swivel head electrodes compensate for minor misalignments and minimize marking of the work surface. RWMA Class 2 is the standard material used, however RWMA Class 1 and 3 are optional. Special sizes and shapes are available upon request.

DOUBLE BEND ELECTRODES

Cadi manufactures double bend electrodes from standard RWMA Class 2 straight electrodes with water tubes in place. This assures water cooling at the weld face, giving longer life and more consistent weld quality. Cadi double bend electrodes may be ordered in all standard nose designs, and, as a special item, in either RWMA Class 1 or 3. Water tubes may be deleted upon request. Special shapes and sizes are available.

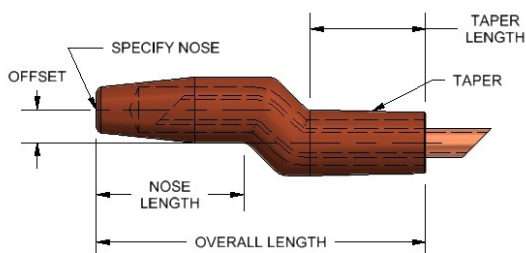

Double bend electrodes are available from 2" to 4" overall length. 4RW or 5RW tapers and offsets to 1-1/4". Standard Nose Length is 3/4" for 4RW and 1" for 5RW. Standard taper length is 7/8" for 4RW and 1" for 5RW. Bent electrode overall length dimensions may vary $\pm 1/16"$. Custom nose length, taper lengths and offsets are available upon request.

OFFSET	TAPER	TAPER LENGTH	NOSE LENGTH	OVERALL LENGTH	PART NUMBER
1/2"	4RW	7/8"	3/4"	2"	CA-2408-8
				2-1/4"	CA-2409-8
				2-1/2"	CA-2410-8
	5RW	1"	1"	2-1/2"	CA-2510-8
				2-3/4"	CA-2511-8
				3"	CA-2512-8
3-1/4"	CA-2513-8				
3/4"	4RW	7/8"	3/4"	2"	CA-2408-12
				2-1/4"	CA-2409-12
				2-1/2"	CA-2410-12
	5RW	1"	1"	2-3/4"	CA-2511-12
				3"	CA-2512-12
				3-1/4"	CA-2513-12
1"	4RW	7/8"	3/4"	2-1/4"	CA-2409-16
				2-1/2"	CA-2410-16
				2-3/4"	CA-2411-16
	5RW	1"	1"	3"	CA-2412-16
				2-3/4"	CA-2511-16
				3"	CA-2512-16
3-1/4"	CA-2513-16				
3-1/2"	CA-2514-16				
1-1/4"	4RW	7/8"	3/4"	2-1/2"	CA-2410-20
				2-3/4"	CA-2411-20
				3"	CA-2412-20
	5RW	1"	1"	2-3/4"	CA-2511-20
				3"	CA-2512-20
				3-1/4"	CA-2513-20
3-1/2"	CA-2514-20				

IRREGULAR SHAPED ELECTRODES

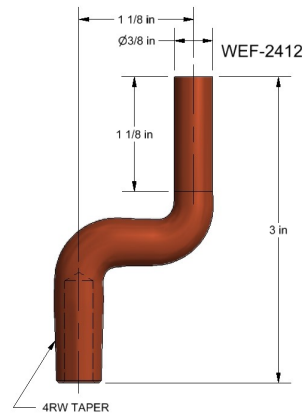
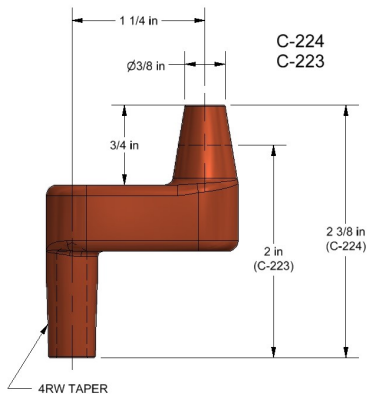
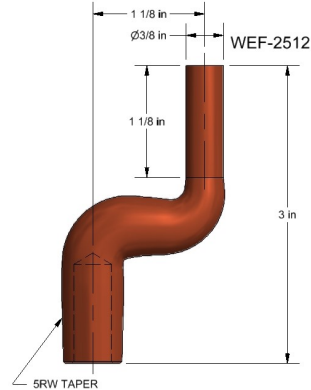
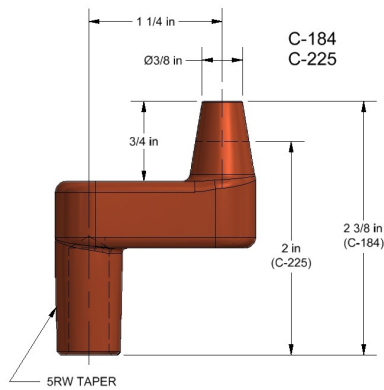

Crank type electrodes are drop forged from RWMA Class 2 copper alloy for additional strength and life. WEF electrodes are cold formed from RWMA Class 2 extruded bar.

30° OFFSET NOSE ELECTRODES

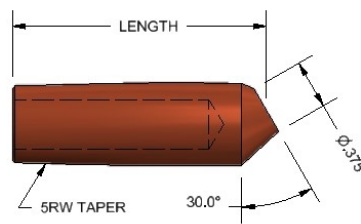
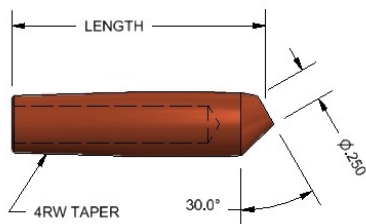

PART NUMBER	TAPER	LENGTH
C-218-2	4RW	2"
C-218-3	4RW	3"
C-218-4	4RW	4"
C-219-2	5RW	2"
C-219-3	5RW	3"
C-219-4	5RW	4"

RWMA Class 2 is the standard material used, however other alloys are available. These electrodes are for use with welder arms having an angled hole. This allows for extra reach into the parts being welded.

SINGLE BEND ELECTRODES

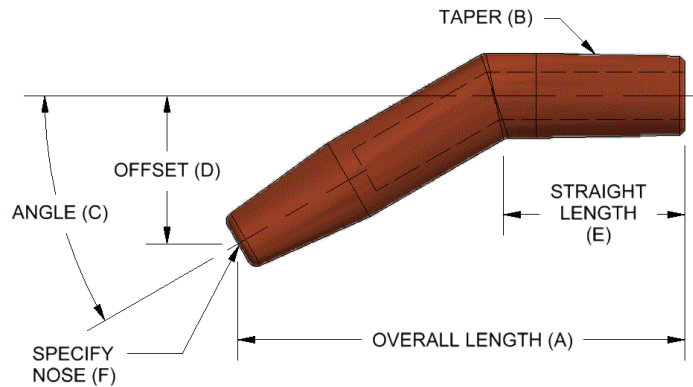

PART NUMBER	OVERALL LENGTH (A)	TAPER (B)	ANGLE (C)	OFFSET (D)	STRAIGHT LENGTH (E)	NOSE TYPE (F)
CA2407-S-15-4-5	1 3/4	4RW	15°	1/4	5/8	A = POINTED (See example below for other nose types)
CA2412-S-15-4-15	3	4RW		1/4	1 7/8	
CA2416-S-15-13-5	4	4RW		13/16	5/8	
CA2508-S-15-4-7	2	5RW		1/4	7/8	
CA2512-S-15-4-15	3	5RW		1/4	1 7/8	
CA2515-S-15-10-8	3 3/4	5RW		5/8	1	
CA2408-S-30-7-6	2	4RW	30°	7/16	3/4	
CA2412-S-30-7-14	3	4RW		7/16	1 3/4	
CA2415-S-30-23-7	3 3/4	4RW		1 7/16	7/8	
CA2508-S-30-9-7	2	5RW		9/16	7/8	
CA2512-S-30-9-15	3	5RW		9/16	1 7/8	
CA2515-S-30-24-8	3 3/4	5RW		1 1/2	1	
CA2407-S-45-10-6	1 3/4	4RW	45°	5/8	3/4	
CA2412-S-45-12-15	3	4RW		3/4	1 7/8	
CA2413-S-45-33-6	3 1/4	4RW		2 1/16	3/4	
CA2508-S-45-17-7	2	5RW		1 1/16	7/8	
CA2512-S-45-17-13	3	5RW		1 1/16	1 5/8	
CA2515-S-45-33-8	3 3/4	5RW		2 1/16	1	
CA2408-S-60-23-7	2	4RW	60°	1 7/16	7/8	
CA2412-S-60-23-15	3	4RW		1 7/16	1 7/8	
CA2411-S-60-40-7	2 3/4	4RW		2 1/2	7/8	
CA2510-S-60-25-9	2 1/2	5RW		1 9/16	1 1/8	
CA2513-S-60-25-15	3 1/4	5RW		1 9/16	1 7/8	
CA2512-S-60-38-10	3	5RW		2 3/8	1 1/4	

Cadi manufactures single bend electrodes from standard RWMA Class 2 straight electrodes. Single bend electrodes may be ordered in all standard nose designs and as a special item in either RWMA Class 1 or 3. Single bend electrodes are available in a wide variety of lengths and offsets. 4RW and 5RW tapers are available. Special shapes and sizes are available. Bent electrode overall length may vary $\pm 1/16"$. "D" DIM=1/16" Increments.

CADI PART NUMBER EXAMPLE: CA2512-S-45-9-10								
	Nose (F)		Taper (B)	Overall Length (A)		Angle of Offset (C)	Offset (D)	Straight Length (E)
C	A	2	5	12	S	45	9	10
Cadi	A = Pointed Nose (other nose types: B = Dome, C = Flat, D = Offset, E = Truncated, F = Radius)	Class 2 Material, other materials available	5RW Taper 4=4RW=(1MT) 5=5RW=(2MT)	12=3" Overall Length in 1/4" increments	Single Bend	45° Angle	9/16 Offset in 1/16" increments	5/8 straight length in 1/8" increments

PADDLE TIP HOLDERS AND SOCKET TIPS

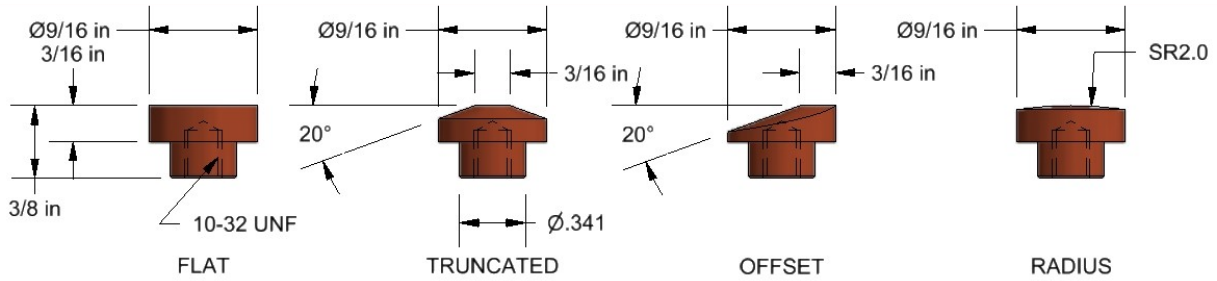

CLASS 2	C194	C195	C196	C197
CLASS 3	C194-CL3	C195-CL3	C196-CL3	C197-CL3

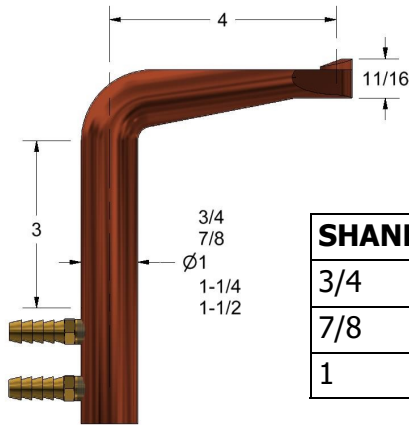

Paddle tip holders accept the socket tips above. They are useful for reaching welds with limited access. With a 4" offset and low head height, they can reach areas not accessible with standard offset holders. A bushing is used so the holder can fit 1-1/2" diameter holes.

SHANK DIA.	PART NUMBER	SHANK DIA.	PART NUMBER
3/4	CPH-75-4	1-1/4	CPH-125-4
7/8	CPH-88-4	1-1/2	CPH-150-4
1	CPH-100-4		

THREADED TIPS

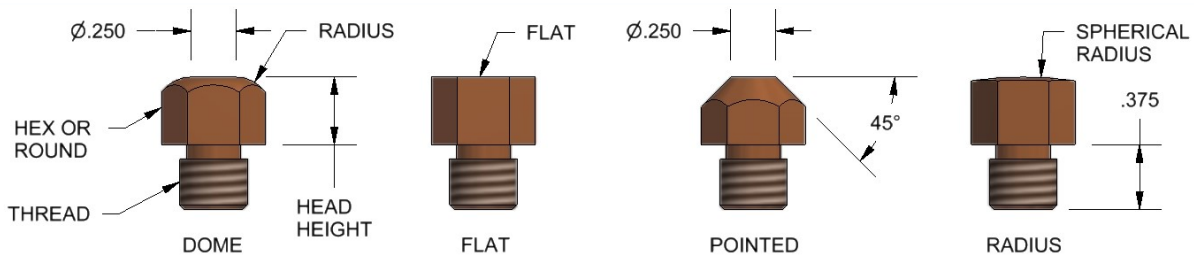

Threaded Tips	Shape	Button	Alloy	Hex Size	Thread	Head Height	-	Face	Additional Info.
	H = Hex R = Round	B = Button	150 181 182 180	37 = 3/8" 43 = 7/16" 50 = 1/2" 56 = 9/16" 62 = 5/8" 75 = 3/4"	25 = 1/4 - 20 31 = 5/16 - 18 37 = 3/8 - 16 43 = 7/16 - 14	25 = 1/4" 31 = 5/16" 37 = 3/8" 43 = 7/16" 50 = 1/2"	-	A = Pointed B = Dome C = Flat F = Radius	Diameter or Radius of Weld Face as Required.
Example:	H	B	182	50	37	37	-	F	2.0 (Radius Dia.)

Cadi Threaded Tips are highly customizable to fit a wide array of applications. Custom shapes and sizes are readily available.

VARIABLE OFFSET HOLDERS

Part #	Diameter
VOH-01000	1"
VOH-01250	1-1/4"
VOH-01500	1-1/2"

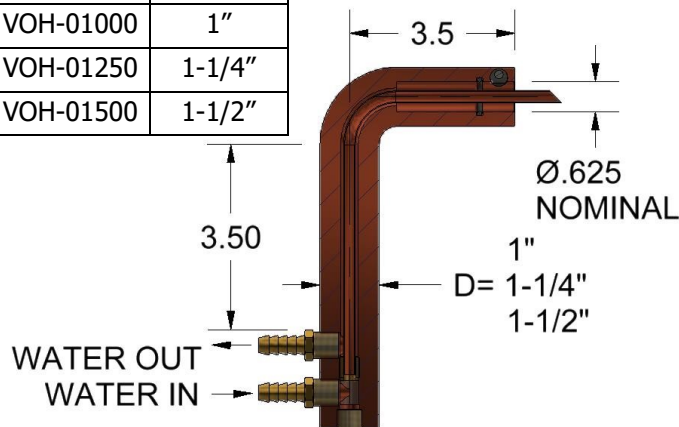

Cadi Variable Offset Holders allow the end user to set the amount of offset across a range, rather than a fixed amount as seen when using 2" or 4" offset holders. Total offset is between 4" and 5".

These holders can be made from Class 2 or 3 copper depending on the application.

Tips are straight shank. They are secured in position with a locking wedge.

VARIABLE OFFSET ADAPTERS AND ELECTRODES

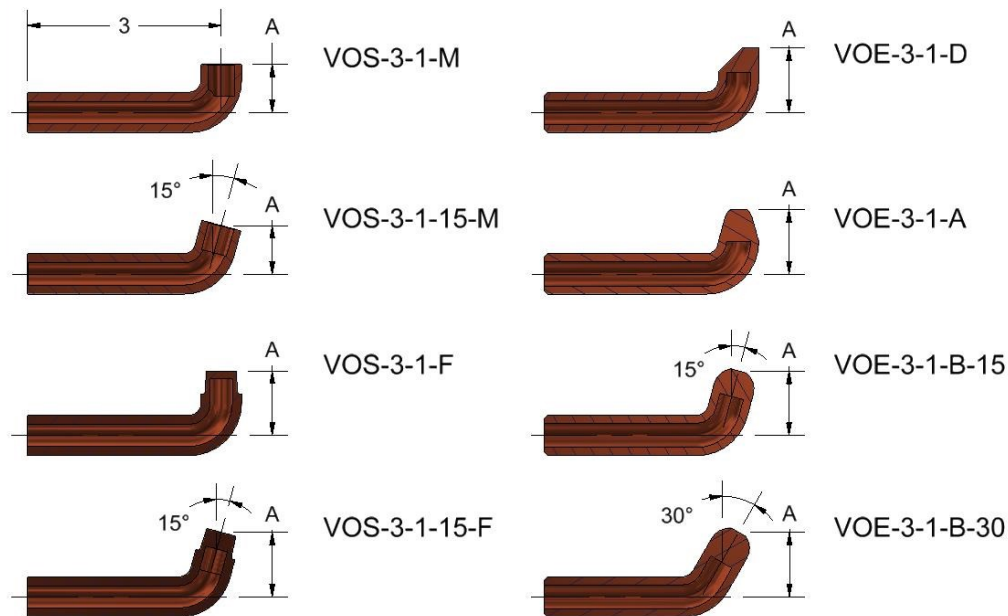

Straight shank electrodes are a one piece design. Straight shank cap adapters are a two piece design and can use any of the 5RW caps seen on pages 5-6. Male cap adapters are made with a thru hole to get water to the cap. Female cap adapters have a blind hole reducing or eliminating spillage when changing caps.

Straight shank electrodes are available with an "A" dimension of 1" or 2". Straight shank cap adapters have a nose length of 3/4" for male adapters and 1" for female adapters. All standard electrodes and adapters are 3" long to the center of the weld face or taper.

Standard material for these items is RWMA Class 2.

Special shapes, sizes and materials are available on request. Contact your Cadi representative for more information.

STUD AND NUT WELDING ELECTRODES

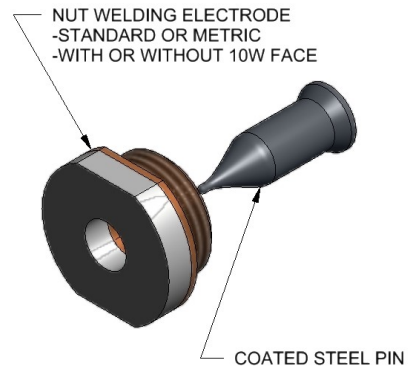
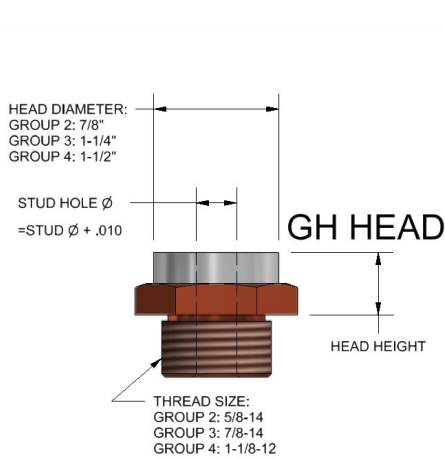

SIZES FROM 4MM THROUGH 15MM.

GH Head	Size	Head Height	Nut or Stud	Face Diameter	Hole Diameter
	Group 2 for Projection Ring Dia. of 7/8 or less Group 3 for Projection Ring Dia. of 1-1/4 or less Group 4 for Projection Ring Dia. of 1-1/2 or less	5 for 1/2" 6 for 5/8"	N= Nut S= Stud	08 = 7/8" 12 = 1-1/4" 15 = 1-1/2"	Hole Diameter = Stud diameter +.010 PIN diameter +.002
Example: GH -	2	5	S	08	323 (hole diameter for 5/16" stud)

Cadi manufactures the highest quality stud and nut electrodes available. Electrodes are available in RWMA Classes 1, 2, 3, and other Copper Alloys and can be faced with copper-tungsten, molybdenum, tungsten and other refractory metals. Hexagon, round with wrench flat, and special shapes and sizes are available.



METRIC NUT WELDING ELECTRODES

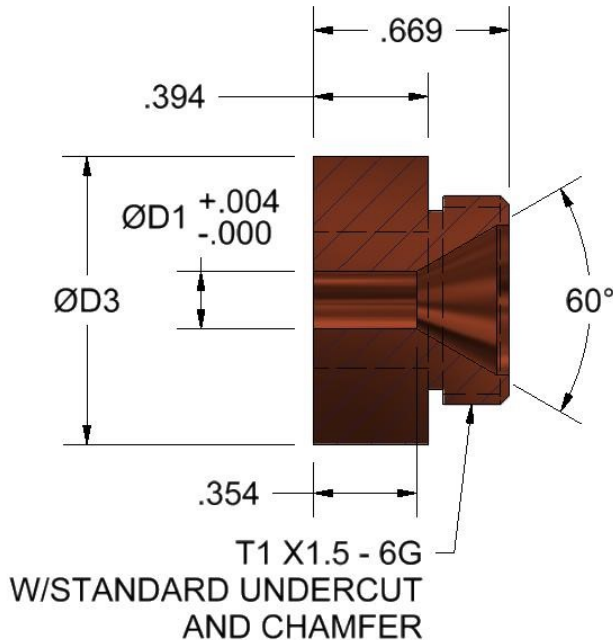

Standard material for nut welding electrodes is RWMA CL2 copper. Optionally, electrode may be faced with copper tungsten, molybdenum, or tungsten. Class 1 or Class 3 is available on request. Hexagon, round with wrench flat, and special shapes and sizes are available.

NUT WELDING ELECTRODES

NUT	PART NUMBER	DIA (D3)	DIA (D1)	THREAD (T1)
4MM	CNWE-M04	25	5	18
5MM	CNWE-M05	25	6	18
6MM	CNWE-M06	25	7	18
7MM	CNWE-M07	25	8	18
8MM	CNWE-M08	25	9	18
9MM	CNWE-M09	25	10	18
10MM	CNWE-M10	30	12	22
11MM	CNWE-M11	30	12	22
12MM	CNWE-M12	30	13	22
13MM	CNWE-M13	30	14	22
14MM	CNWE-M14	32	15	26
15MM	CNWE-M15	32	16	26
16MM	CNWE-M16	32	16	26
16MM	CNWE-M16.5	32	16.5	26

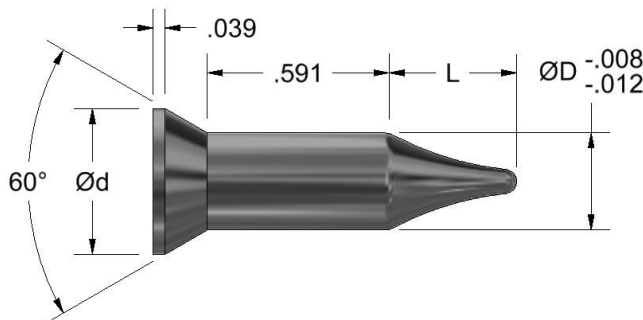

Cadi guide pins are made to the highest standards. Our insulating coating process is designed to increase the life of the pin, while providing excellent electrical insulation.

We can make any special design you need, in the quantities you require.

Many pins are in stock and available for immediate delivery. Call your Cadi representative today for a competitive quote.

METRIC GUIDE PINS

NUT	PART NUMBER	DIA (D)	LENGTH (L)	DIA (d)
4MM	CGP-M04	5.0	5.5	12
5MM	CGP-M05	6.0	7.5	12
6MM	CGP-M06	7.0	9.5	12
7MM	CGP-M07	8.0	10.5	12
8MM	CGP-M08	9.0	11.0	12
9MM	CGP-M09	10.0	11.0	12
10MM	CGP-M10	11.0	12.0	16
11MM	CGP-M11	12.0	13.5	16
12MM	CGP-M12	13.0	15.0	16
13MM	CGP-M13	14.0	15.0	16
14MM	CGP-M14	15.0	16.0	21
15MM	CGP-M15	16.0	16.0	21
16MM	CGP-M16	17.0	17.0	21
16MM	CGP-M16.5	16.5	17.0	21

METRIC NUT WELDING HOLDERS



LOWER ELECTRODE HOLDER

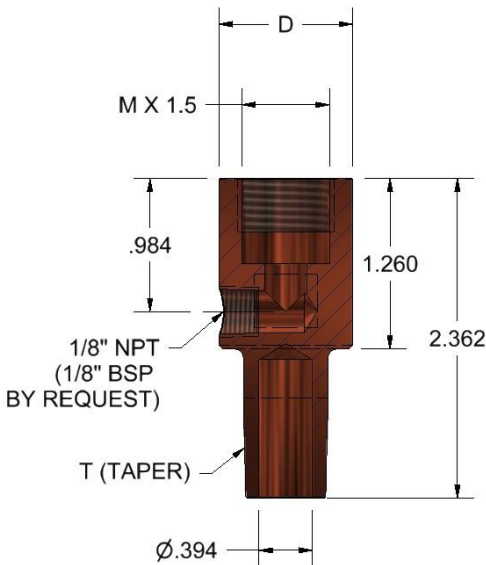

PART NUMBER	DIA (D)	TAPER (T)	THREAD (M)
CNWH-25A	25MM	MT #1	18
CNWH-25B	25MM	1/10	18
CNWH-25C	25MM	MT #2	18
CNWH-25C-THD	25MM	5/8-11	18
CNWH-30A	30MM	MT #2	22
CNWH-30B	30MM	1/10	22
CNWH-35A	35MM	MT #2	26

Choose the holder required based on the thread of the nut welding electrode and taper of the machine's electrode holder. Cadi's Lower Electrode Holders are all made from RWMA Class 2. Threaded holder length will vary.

STUD WELDING ELECTRODES

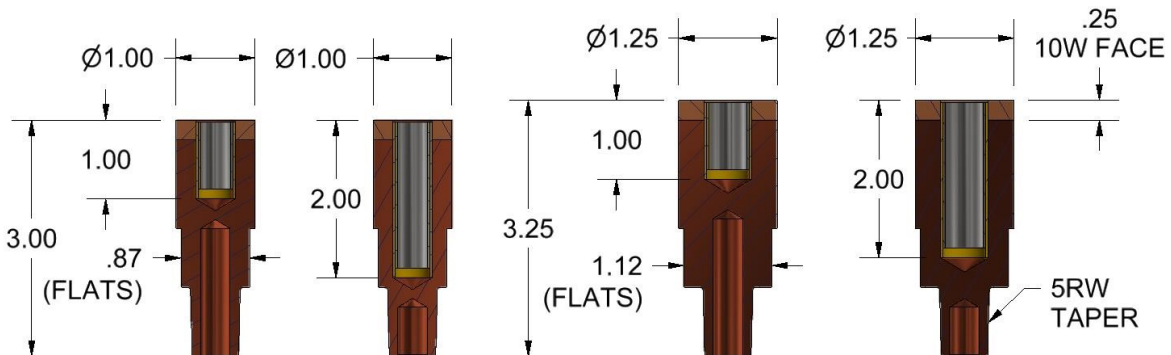

1" DEEP HOLE 1" DIAMETER			2" DEEP HOLE 1" DIAMETER			1" DEEP HOLE 1.25" DIAMETER			2" DEEP HOLE 1.25" DIAMETER		
SCREW SIZE	ID	PART NUMBER	SCREW SIZE	ID	PART NUMBER	SCREW SIZE	ID	PART NUMBER	SCREW SIZE	ID	PART NUMBER
6MM	.243	CSWE-236-1	6MM	.243	CSWE-236-2	.437	.444	CSWE-444-1	.437	.444	CSWE-444-2
.250	.256	CSWE-256-1	.250	.256	CSWE-256-2	12MM	.479	CSWE-479-1	12MM	.479	CSWE-479-2
.312 8MM	.319	CSWE-319-1	.312 8MM	.319	CSWE-319-2	.500	.506 .569	CSWE-506-1	.500	.506 .569	CSWE-506-2
.375	.381	CSWE-381-1	.375	.381	CSWE-381-2	.625	.652 .694 .777	CSWE-652-1 CSWE-694-1 CSWE-777-1	.625	.652 .694 .777	CSWE-652-2 CSWE-694-2 CSWE-777-2
10MM	.400	CSWE-400-1	10MM	.400	CSWE-400-2						

Cadi stud welding electrodes are made with a Class 2 body and a long-lasting 10W copper tungsten weld face. Insulation is made with long-life materials for extended service.

SEAM WELD WHEELS AND BLANKS

Cadi Company is an ISO certified manufacturer and distributor of seam weld wheel blanks and finished wheels using RWMA Copper Alloys.

Cadi Company has:

- A tailored process for individually hot forging blanks consistent with best metallurgical processes.
- A proprietary process that yields maximum hardness while maintaining necessary ductility.
- A metallurgically engineered process that yields optimum grain structure.

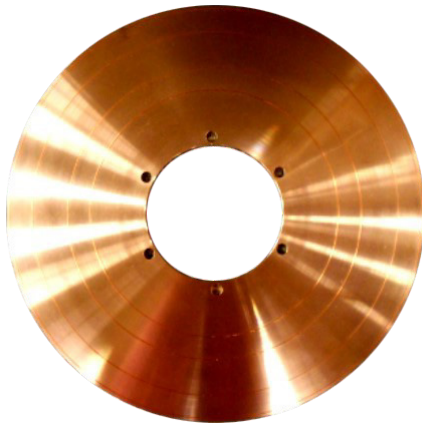

Cadi weld wheels are made from RWMA Class 2 (C18150 and C18200) and RWMA Class 3 (C18000 and C17510) copper alloys. Cadi Class 2 wheels are specially forged to increase hardness to R75_B minimum. Wheel blanks are in stock to 30" in diameter. Machined forgings are available for:

- weld wheels and shafts
- flash/butt welding arms and dies
- various arms and platen mounts
- other custom parts from print

Cadi understands the metallurgical issues of seam welding wheel manufacturing. We have applied this knowledge to develop a proprietary process that consistently delivers quality seam welding wheels for demanding applications.

RWMA CLASS	UNS	Hardness R _B	Electrical Conductivity %IACS	Applications
Class 2	C18200 CuCr	65 min	75 min	Hot-rolled steel
Class 2 Premium	C18150 CuCrZr	75 min	75 min	Coated Materials Galvanized Steel
	C18200 CuCr			Premium grade for hot-rolled steel used with higher pressures
Class 3	C18000 CuNiSiCr (Beryllium free)	90 min	45 min	Stainless Steel High temperature Steels
	C17510 CuNiBe			

WIRE MESH WELDING DIES

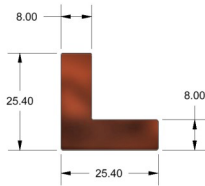

SP00199

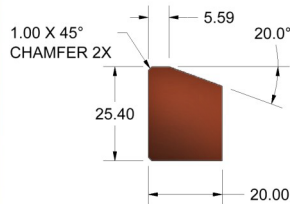

SP00196

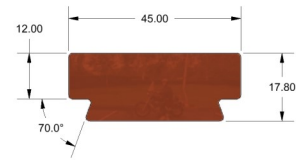

SP00198

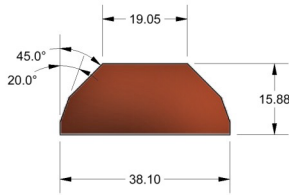

D-1

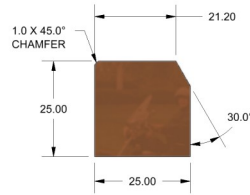

MG 215

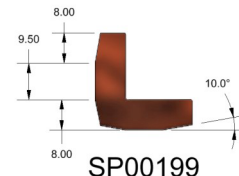

SP00199
MOD 1

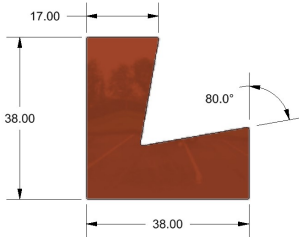

SP00202

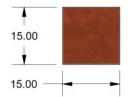

15 X 15

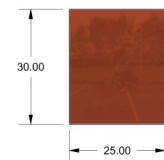

25 X 30

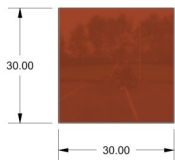

30 X 30

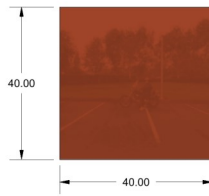

40 X 40



40 OCTAGON

Other standard shapes and custom designs may be made to order.

Cadi stocks a complete line of extruded and machined welding dies for various mesh welding machines. These shapes are primarily stocked in RWMA Class 3 (C18000). The material can be supplied as finished electrodes made to print or as bar stock ready for your individual application. Available in any length up to a 12 ft. mill length. Cadi has prints for dozens of various custom mesh welding electrodes, holders, shunts and other supports.



ELECTRODE ADAPTORS

1/2" NPT THREAD

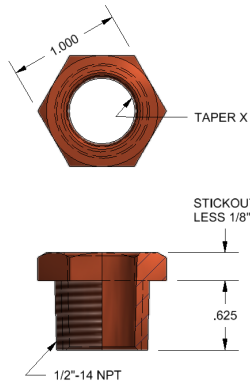

For best results, always use Cadi Coppr-Lube to seal NPT threads.

STRAIGHT THREAD WITH O-RING

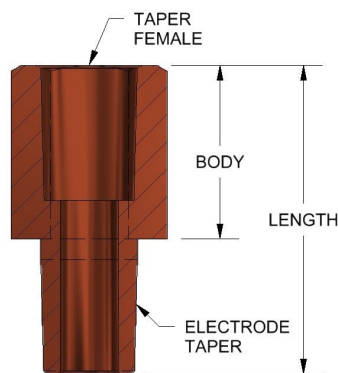
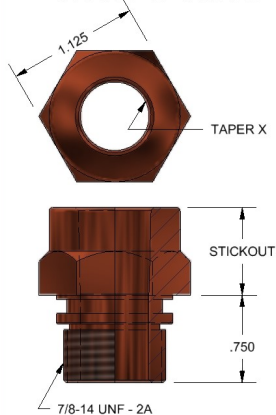

1/2" & 5/8" NPT ADAPTORS

Part No.	Length	Stickout	Thread Size	
HA182-100-050P-087-4RW HA182-100-050P-087-5RW	7/8"	3/8"	1/2" NPT	
HA182-100-050P-112-4RW HA182-100-050P-112-5RW	1-1/8"	1/2"		
HA182-100-050P-137-4RW HA182-100-050P-137-5RW	1-3/8"	3/4"		
HA182-100-050P-162-4RW HA182-100-050P-162-5RW	1-5/8"	1"		
HA182-100-050P-187-4RW HA182-100-050P-187-5RW	1-7/8"	1-1/4"		
HA182-100-050P-212-4RW HA182-100-050P-212-5RW	2-1/8"	1-1/2"		
HA182-100-050P-237-4RW HA182-100-050P-237-5RW	2-3/8"	1-3/4"		
HA182-100-050P-262-4RW HA182-100-050P-262-5RW	2-5/8"	2"		
HA182-100-062P-087-4RW HA182-100-062P-087-5RW	7/8"	3/8"		5/8" NPT
HA182-100-062P-112-4RW HA182-100-062P-112-5RW	1-1/8"	1/2"		
HA182-100-062P-137-4RW HA182-100-062P-137-5RW	1-3/8"	3/4"		

Cadi manufactures a wide variety of electrode adaptors for most applications.

Adaptors are designed to fit standard tip holders as well as barrel holders on multi-gun welders.

In addition to the NPT threads 1/2-14 and 5/8-14, we also have 3/4-14 NPT threaded adaptors available in many of the same lengths.

Cadi also manufactures 1-12 straight thread adaptors in two different configurations; one with a 3/8" tall hex, and the other with an 11/16" tall hex. All straight thread adaptors are supplied with the correct o-ring.

Standard material for Cadi electrode adaptors is RWMA Class 2. Class 1 and Class 3 are available as an option.

For a complete listing, reference the **Cadi Cylinder Mounted Welding Accessories Catalog** on the Cadi website under technical resources or contact Cadi for a printed copy.

7/8"-14 ADAPTORS

Part No.	Length	Stickout	Thread Size
HA182-112-087S-112-X	1-1/8"	3/8"	7/8-14
HA182-112-087S-125-X	1-1/4"	1/2"	
HA182-112-087S-137-X	1-3/8"	5/8"	
HA182-112-087S-150-X	1-1/2"	3/4"	
HA182-112-087S-162-X	1-5/8"	7/8"	
HA182-112-087S-175-X	1-3/4"	1"	
HA182-112-087S-187-X	1-7/8"	1-1/8"	
HA182-112-087S-200-X	2"	1-1/4"	
HA182-112-087S-212-X	2-1/8"	1-3/8"	
HA182-112-087S-225-X	2-1/4"	1-1/2"	
HA182-112-087S-237-X	2-3/8"	1-5/8"	
HA182-112-087S-250-X	2-1/2"	1-3/4"	
HA182-112-087S-262-X	2-5/8"	1-7/8"	

(X) = 4 for 4RW TAPER
5 for 5RW TAPER

TAPER TO TAPER ADAPTORS

Part No.	Length	Body	ELECTRODE TAPER	TAPER FEMALE
HA182-112-5RW-112-4RW	1-1/8"	1/4"	5RW	4RW
HA182-112-5RW-200-4RW	2"	1"	5RW	4RW
HA182-112-5RW-250-4RW	2-1/2"	1-1/2"	5RW	4RW
HA182-112-5RW-300-4RW	3"	2"	5RW	4RW
HA182-112-5RW-400-4RW	4"	3"	5RW	4RW
HA182-112-5RW-200-5RW	2"	1"	5RW	5RW
HA182-112-5RW-250-5RW	2-1/2"	1-1/2"	5RW	5RW
HA182-112-5RW-300-5RW	3"	2"	5RW	5RW
HA182-112-5RW-400-5RW	4"	3"	5RW	5RW
HA182-112-5RW-500-5RW	5"	4"	5RW	5RW
HA182-112-4RW-237-5RW	2"	1"	4RW	5RW

CYLINDER MOUNTED WELDING ACCESSORIES

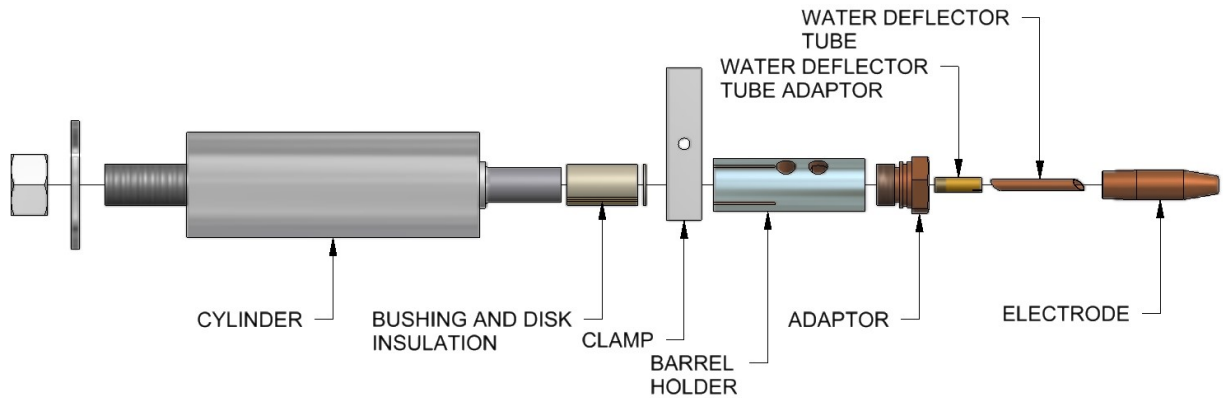

STRAIGHT ELECTRODE HOLDERS

CLAMPS/LUGS

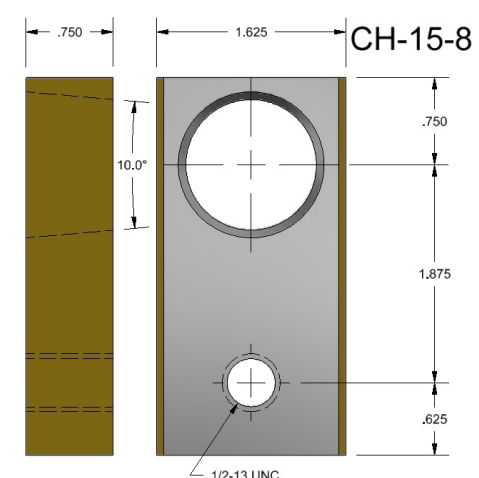
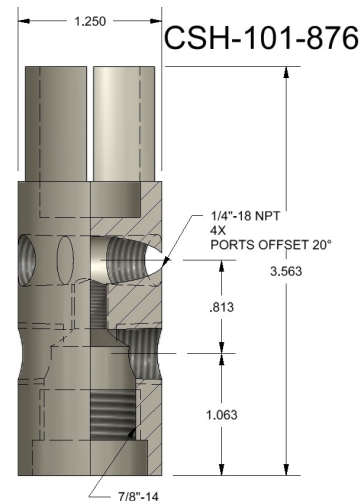
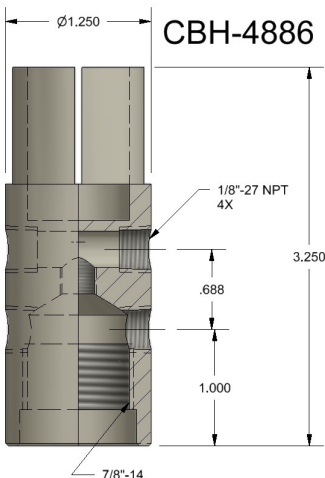
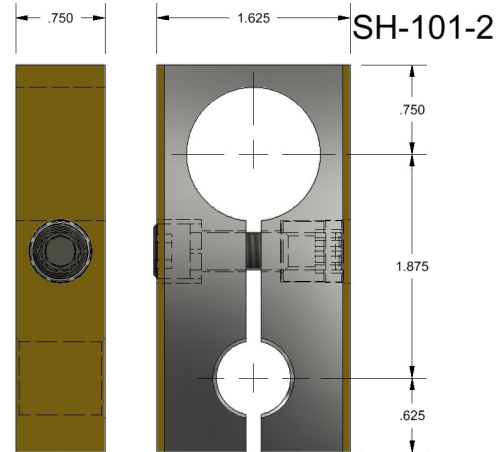
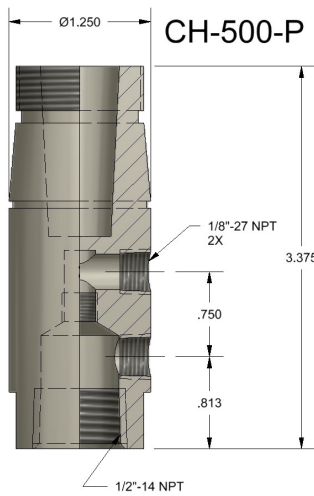
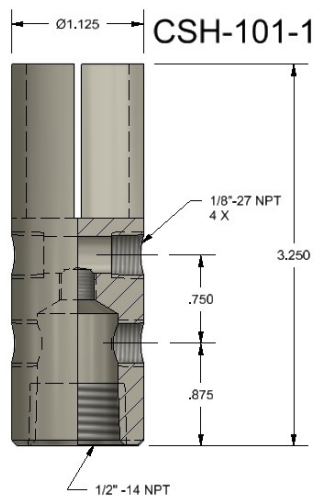

Cadi offers straight holders and clamps in a variety sizes and shapes. Our straight holders and clamps are all silver plated for optimum conductivity. Adapter threads may be NPT or straight with an O-ring. For a complete listing, reference the **Cadi Cylinder Mounted Welding Accessories Catalog** on the Cadi website under technical resources or contact Cadi for a printed copy.

Cadi Company, Inc. P.O. Box 1127, 60 Rado Drive, Naugatuck, CT 06770
www.cadicompany.com 800-243-3650 203-729-1111



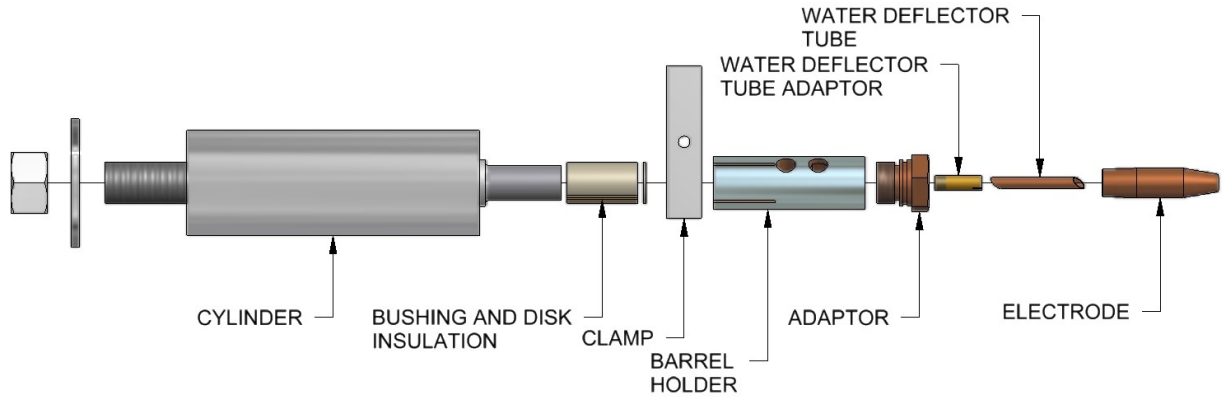

OFFSET ELECTRODE HOLDERS

STANDARD INSULATION

SERIES 5 OFFSET HOLDER

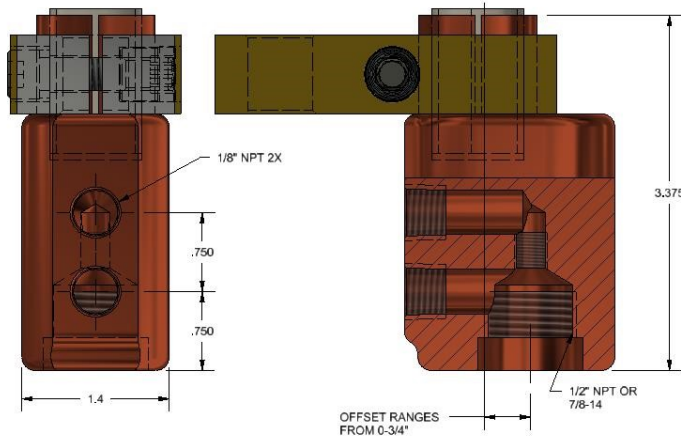

CSH-101

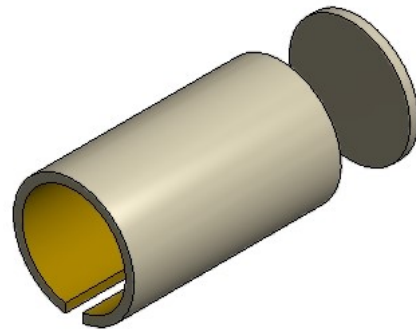

SERIES 6 OFFSET HOLDER

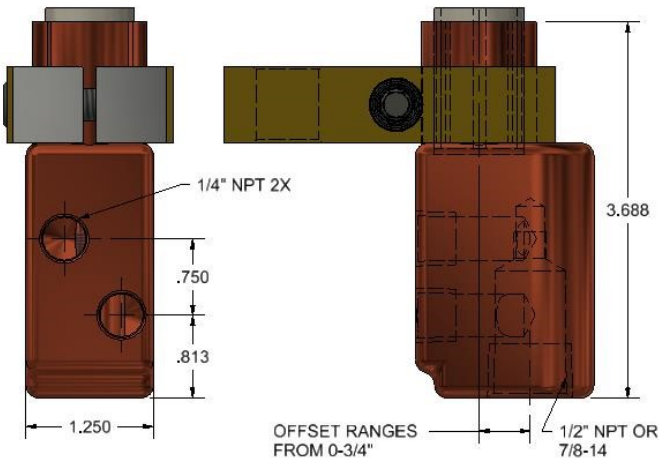

SERIES H

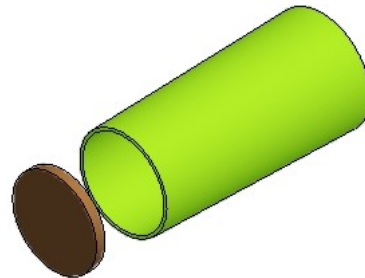

Cadi manufactures a complete line of offset electrode holders. Many different heights and offsets are available. Adapter threads may be NPT or straight with an O-ring. For a complete listing, reference the **Cadi Cylinder Mounted Welding Accessories Catalog** on the Cadi website under technical resources or contact Cadi for a printed copy.

CYLINDER MOUNTED WELDING ACCESSORIES

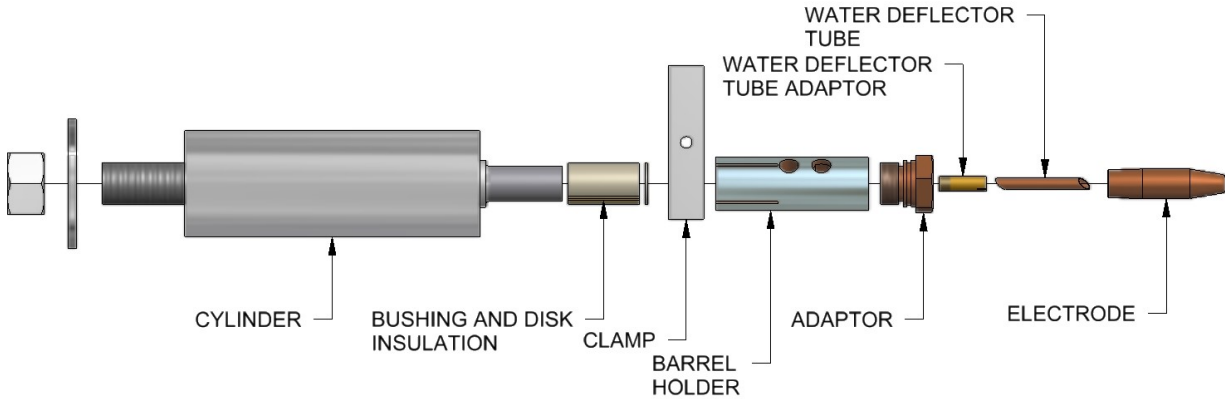

WATER DEFLECTOR TUBE ADAPTORS	
Part No.	Length
SF-101-6	3/4"
SF-101-8	1"
SF-101-10	1-1/4"
SF-101-12	1-1/2"
SF-101-14	1-3/4"
SF-101-16	2"
SF-101-18	2-1/4"
SF-101-20	2-1/2"
SF-101-22	2-3/4"
SF-101-24	3"
SF-101-26	3-1/4"
SF-101-28	3-1/2"

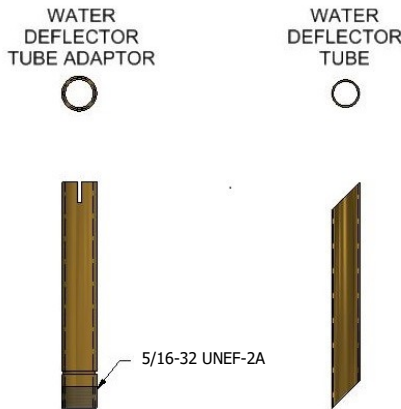

WATER DEFLECTOR TUBES		
Part No.	Length	TAPER
SF-201-5	1-1/4"	4RW
SF-201-6	1-1/2"	4RW
SF-201-7	1-3/4"	4RW
SF-201-8	2"	4RW
SF-201-9	2-1/4"	4RW
SF-201-10	2-1/2"	4RW
SF-201-11	2-3/4"	4RW
SF-201-12	3"	4RW
SF-201-11	3-1/4"	4RW
SF-201-14	3-1/2"	4RW
SF-202-5	1-1/4"	5RW
SF-202-6	1-1/2"	5RW
SF-202-7	1-3/4"	5RW
SF-202-8	2"	5RW
SF-202-9	2-1/4"	5RW

Cadi water tubes are made to the exact specifications you require. We make all of the standard lengths and special lengths per your application.



CADI COPPR-LUBE is a paste-like lubricant that provides an effective solution to prevent galling and seizing of components in resistance welding environments. It applies easily as a paste by brush which allows it to flow easily into threads and cavities.

WATER COOLED CABLES

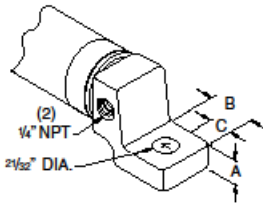

TYPE B

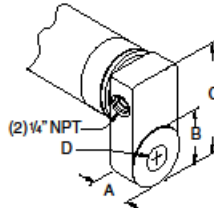

TYPE B-2

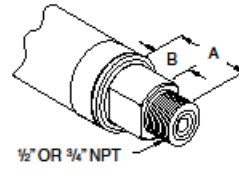

TYPE B-4

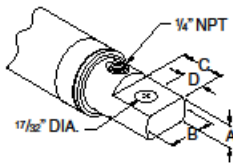

TYPE B-5

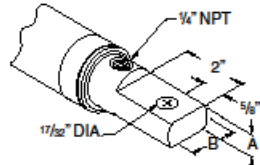

TYPE B-6

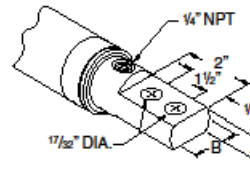

TYPE B-6 (2-HOLE)

WATER COOLED:

All water cooled cables come equipped with a full length filter tube to ensure free flow water passage through the entire length of the cable. Extreme bending or kinking of the cable will not restrict water flow.

Cables are available from 350 MCM to 1000 MCM.

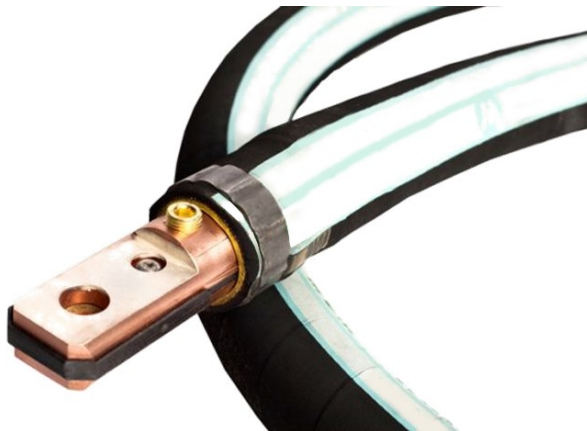

KICKLESS:

A special design combines the low reactance feature of an alternate-polarity cross section with a unique connection on the terminal end. The result is a high-performance, long-life cable suitable for the high standards and demands of the automotive and appliance industries.

Cables are available from 300 MCM to 650 MCM.

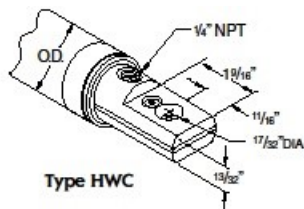

Type HWC

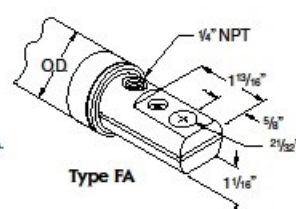

Type FA

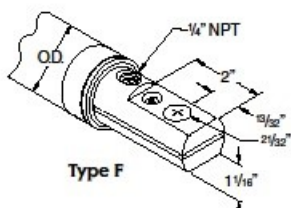

Type F

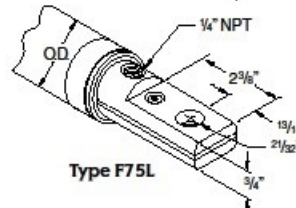

Type F75L

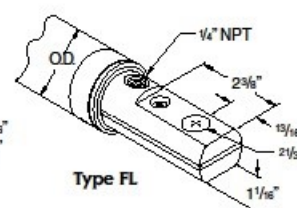

Type FL

AIR COOLED CABLES

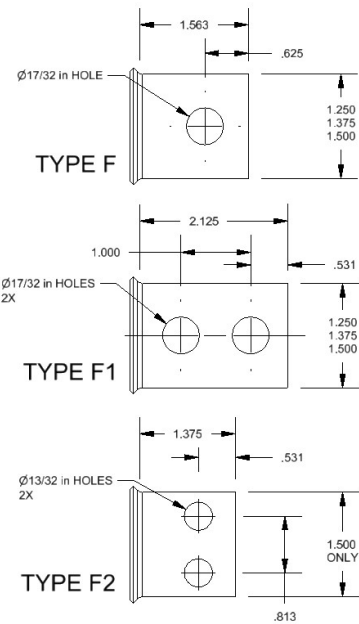
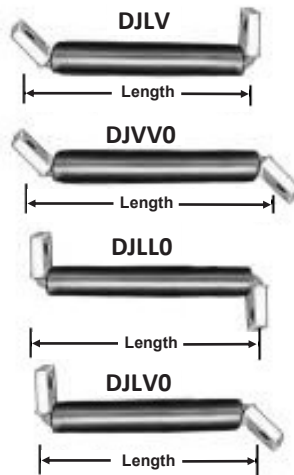
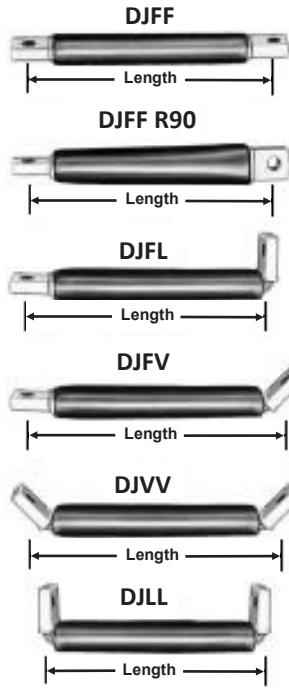

Air cooled cables (DJ) provide an economical alternative for lighter duty applications not requiring water cooled cables.

The length is measured from the bolt hole centers on straight or 45° terminals. On terminals with 90° bends, measure to the extreme outside edge. On terminals with two holes, measure to the center of the outer holes.

Standard terminal width is 1-1/4". 1-3/8" and 1-1/2" are available; specify when ordering.

Cables are also available as DJ-IC Isolated Conductor (each individual rope is in rubber tubing), DJ-SC Stabilized Collar (reduces strand failure at the cable terminal) and DJ-XF (36 AWG Copper Rope).

DJ-IC eliminates frictional wear by use of rubber tubing for each rope.

DJ-SC uses a Stabilizer Flare on the terminal to reduce stress on the cable ends. This significantly reduces strand failure at the terminal.

DJ-XF uses 36 AWG strand rope and an extremely flexible protective cover. The DJ-XF is twice as flexible as the standard DJ air cooled cable.

Air cooled cables are available from 350 MCM to 2000 MCM cross sections.

LAMINATED SHUNTS

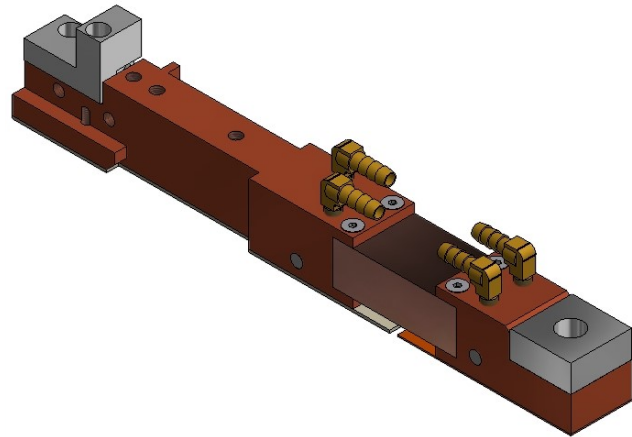
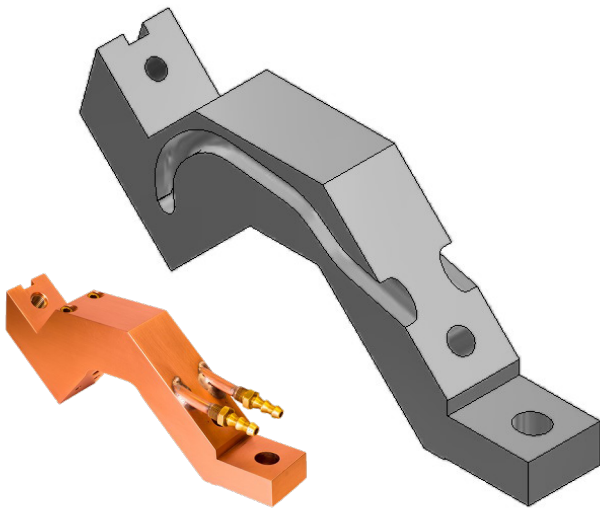
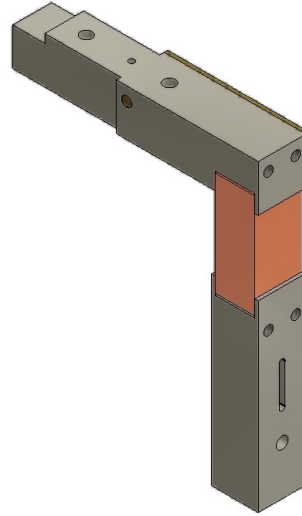
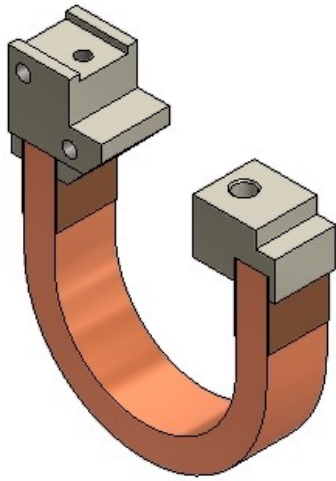





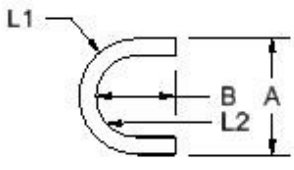
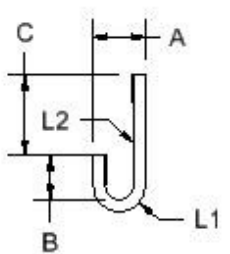
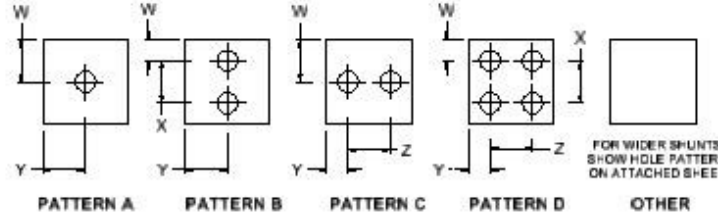
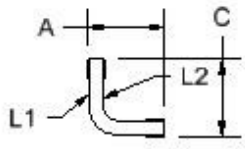
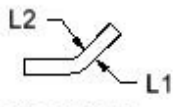

Cadi manufactures a wide assortment of special copper shunts. We can produce any shunt from your drawing, or reverse engineer the part from your sample.

We can also refurbish old shunts having worn or missing laminations. Very expensive shunts may not need to be replaced, just repaired.

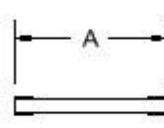
LAMINATED SHUNT SELECTION FORM



 <p>"C" SHUNT</p>	<h2 style="text-align: center;">SHUNT SPECIFICATIONS:</h2> <p>TYPE: (CIRCLE ONE) PRESS WELDED RIVETED</p> <p>STYLE (CIRCLE ONE): "C" "J" "L" "V" "FLAT"</p> <p>THICKNESS OF STACK _____ SHUNT WIDTH _____ A _____ B _____ C _____</p> <p>LENGTH: L1 OUTSIDE LENGTH _____ L2 INSIDE LENGTH _____</p> <p>MATERIAL THICKNESS: .005 .010</p>										
 <p>"J" SHUNT</p>	 <p style="text-align: center;">PATTERN A PATTERN B PATTERN C PATTERN D OTHER</p> <p>FOR WIDER SHUNTS, SHOW HOLE PATTERN ON ATTACHED SHEET.</p>										
 <p>"L" SHUNT</p>	<p>HOLE PATTERN (CIRCLE ONE): <input type="checkbox"/> A <input type="checkbox"/> B <input type="checkbox"/> C <input type="checkbox"/> D <input type="checkbox"/> OTHER</p> <p>DIMENSION: "W" _____ "X" _____ "Y" _____ "Z" _____</p> <p>HOLE DIAMETER _____</p> <p>END CLIP (.062" THICK STANDARD) (INDICATE STYLE WITH DIMENSION)</p>										
 <p>"V" SHUNT 45°</p>	<p>DIMENSION: NO FLARE: _____ FLARE: _____ </p> <p>COVER OPTION: TEFLON FIBERGLASS</p> <p>PLATING OPTION: SILVER TIN OTHER _____</p> <p>QUANTITY: _____</p> <p>COMPANY NAME: _____</p> <p>ADDRESS: _____</p> <p>CITY: _____ STATE _____ ZIP _____</p> <p>PHONE: _____ FAX: _____</p> <p>CONTACT NAME: _____</p> <p>EMAIL ADDRESS: _____</p>										
 <p>"FLAT" SHUNT</p>	<table border="1" style="width: 100%; border-collapse: collapse;"> <tr> <td colspan="2" style="text-align: center;">TITLE</td> </tr> <tr> <td colspan="2" style="text-align: center; font-size: 1.2em;">LAMINATED SHUNT FORM</td> </tr> <tr> <td style="text-align: center;">  </td> <td style="text-align: center;"> CADI COMPANY, INC. 60 RADO DRIVE NAUGATUCK, CT 06770 </td> </tr> <tr> <td style="text-align: center;"> SIZE A </td> <td style="text-align: center;"> DWG NO </td> </tr> <tr> <td style="text-align: center;"> SCALE </td> <td style="text-align: center;"> REV </td> </tr> </table>	TITLE		LAMINATED SHUNT FORM			CADI COMPANY, INC. 60 RADO DRIVE NAUGATUCK, CT 06770	SIZE A	DWG NO	SCALE	REV
TITLE											
LAMINATED SHUNT FORM											
	CADI COMPANY, INC. 60 RADO DRIVE NAUGATUCK, CT 06770										
SIZE A	DWG NO										
SCALE	REV										
4	3	2	1								

Use the form above to specify your laminated shunt. Return to your Cadi representative for a fast, competitive quote.

WELD CONTROLS AND WATER CHILLERS



Cadi supplies a wide range of weld controls for retro-fit or new installations.

Single phase, three phase, and mid-frequency are available.

Controls are available in many configurations and cabinet sizes:

- Single SCR
- Cascade (up to 8 SCRs)
- Multiple Controls in a Single Cabinet
- Flat Pack (No Cabinet)
- Constant Current
- With or Without a Circuit Breaker

Installation is available.



Water chillers are available in a wide assortment of sizes and configurations.

- Refrigerated Models Start at 2 Tons
- Self-Contained Recirculating Pumps
- Digital Temperature Controllers
- Vertical Air Discharge
- Cleanable Air Filters
- Brazed Plate Evaporator
- Powder Coated Cabinet

COPPER ALLOY BAR STOCK



Large supply of ready-to-ship rod, bar, plate, all shapes and sizes.

RWMA Class	UNS	Copper Alloy
Class 1	C15000	Copper Zirconium
Class 2	C18200	Copper Chromium
Class 2	C18150	Copper Chromium Zirconium
Class 3	C17510	Copper Nickel Beryllium
Class 3	C18000	Copper Nickel Silicon Chromium (Beryllium Free)
Class 4	C17200	Copper Beryllium
Class 20	C15760	Dispersion Strengthened Copper

Cadi Company is an ISO certified manufacturer and distributor of high conductivity copper alloys. We specialize in copper that is used to manufacture resistance welding components; such as welding wheels, electrodes, and numerous other applications that demand the performance beyond the capabilities of standard coppers.

Typical Usages of RWMA Copper Alloys:

Class 1: Recommended for spot welding of coated steels and high conductivity materials, excluding copper and silver.

Class 2: Recommended for spot and seam welding, cold and hot rolled steels, coated materials, current carrying shafts and arms, back-up bars for both resistance and arc welding, and electrical current carrying structural parts.

Class 3: Recommended for spot and seam welding of high resistance alloys such as stainless steel. Other uses include flash welding dies, back-up bars, and projection welding electrodes.

Class 4: Recommended for flash and upset welding dies, projection welding and seam welding bushings and other applications requiring harder copper alloy.

Class 20: Welding of metallic coated metals, most commonly galvanized steel.

REFRACTORY METALS



Refractory metals

- ◆ Class 10 (30% Cu), 11 (25% Cu), and 12 (20% Cu) are sintered metals of copper and tungsten.
- ◆ These combinations produce dense, hard metals with optimum wear resistance and strength at high temperatures.
- ◆ Good thermal and electrical conductivity.
- ◆ Used as facing material on copper alloy electrodes.
- ◆ The additional cost of these refractory metals is outweighed by the lower production cost per weld due to longer tool life, less electrode dressing time, and high stability which provides uniform heating and prevents misalignments for higher weld quality.

RWMA Class	Alloy Number	Copper Alloy
Class 10	N/A	Copper Tungsten
Class 11	ASTM B702 C1D	Copper Tungsten
Class 12	ASTM B702 C1E	Copper Tungsten
Class 13	N/A	Tungsten
Class 14	ASTM B387 TYPE 360	Molybdenum

Typical Uses of Refractory Metals:

Class 10: Recommend for flash and butt welding die inserts, spot welding low conductivity ferrous metals (for example stainless steel).

Class 11: Recommended for electrodes and die inserts in most flash and butt welding dies and for projection welding dies with moderate weld pressure and light electrical upsetting, electro-forging dies.

Class 12: Recommended for high volume projection welding dies with high pressure, electrical upsetting of non-ferrous metals and low carbon steel like die facings.

Class 13: Recommended for cross-wire welding of metals such as copper and brass. Also used for electro blazing electrode material and some electrical upsetting operations.

Class 14: Recommended for electro brazing electrode material and cross-wire welding of nonferrous metals. Also used as an electrode for welding or brazing of braided or solid copper conductors to ferrous or nonferrous terminals, lugs or fittings.

COPPER ALLOYS PHYSICAL PROPERTIES



Physical & Mechanical Properties Group A (Class 1, 2, 3, 4)									
Group A Copper Base Alloys ¹		Minimum Hardness Rockwell B or C as noted ²				Minimum Electrical Conductivity % IACS [MS/m]			
Size Range		Class				Class			
IN	MM	1	2	3	4	1	2	3	4
Diameter - Round Bar Stock									
Up to 1"	Up to 25	65 HRB	75 HRB	90 HRB	33 HRC	80% [46]	75% [43.5]	45% [26]	20% [11.6]
Over 1"-2"	Over 25-51	60 HRB	70 HRB	90 HRB	33 HRC	80% [46]	75% [43.5]	45% [26]	20% [11.6]
Over 2"-3"	Over 51-76	55 HRB	65 HRB	90 HRB	33 HRC	80% [46]	75% [43.5]	45% [26]	20% [11.6]
Over 3"-3 1/2"	Over 76-89	50 HRB	65 HRB	90 HRB	33 HRC	80% [46]	75% [43.5]	45% [26]	20% [11.6]
Over 3-1/2" - 4"	Over 89 - 102	48 HRB	60 HRB	90 HRB	33 HRC	80% [46]	75% [43.5]	45% [26]	20% [11.6]
Over 4" - 4-1/2"	Over 102-114	45 HRB	60 HRB	90 HRB	33 HRC	80% [46]	75% [43.5]	45% [26]	20% [11.6]
Thickness - Square, Rectangular & Hexagonal Bar Stock									
Up to 1"	Up to 25	55 HRB	70 HRB	90 HRB	33 HRC	80% [46]	75% [43.5]	45% [26]	20% [11.6]
Over 1"	Over 25	50 HRB	65 HRB			80% [46]	75% [43.5]	45% [26]	20% [11.6]
Thickness - Forgings and Plates									
Up to 1"	Up to 25	55 HRB	65 HRB	90 HRB	33 HRC	80% [46]	75% [43.5]	45% [26]	20% [11.6]
Over 1" to 2"	Over 25 - 51	50 HRB	65 HRB	90 HRB	33 HRC	80% [46]	75% [43.5]	45% [26]	20% [11.6]
Over 2"	Over 51	50 HRB	65 HRB	90 HRB	33 HRC	80% [46]	75% [43.5]	45% [26]	20% [11.6]

Reference: AWS J1.3/J1.3M-2020 Table 5

¹ All materials are in a fully heat treated condition unless otherwise specified.

² Round Rod tested at mid radius in accordance with ASTM test method E18.

COPPER ALLOYS PHYSICAL PROPERTIES

CHEMICAL COMPOSITIONS OF RWMA MATERIALS GROUP A— COPPER BASE ALLOYS												
	UNS #	DESCRIPTION	Cu ¹	Fe	Co	Ni	Cr	Si	Be	Pb	Zr	Al
1	C15000	COPPER ZIRCONIUM	99.80 MIN.								0.10-0.20	
2	C18150	COPPER CHROMIUM ZIRCONIUM	Bal.				0.5-1.5				0.02-0.20	
	C18200	COPPER CHROMIUM	Bal.	0.10 max			0.6-1.2	0.10 max		0.50 max		
3	C17500	COPPER BERYLLIUM COBALT	Bal.	0.10 max		2.4-2.7		0.20 max	0.4-0.7			0.20 max
	C17510	COPPER NICKEL BERYLLIUM	Bal.	0.10 max	1.4-2.2	0.30 max		0.20 max	0.2-0.6			0.20 max
	C17540	COPPER NICKEL COBALT BERYLLIUM	Bal.	0.20 max	0.8-1.3	0.8-1.3			0.4-0.7			
	C18000	COPPER NICKEL SILICON CHROMIUM	Bal.	0.15 max	1.8-3.0		0.1-0.8	0.4-0.8				
4	C17200	COPPER BERYLLIUM	Bal.		Ni +Co= 0.20 min. Ni+Fe+Co=0.60 max		0.20 max	1.8-2.0	0.02 max		0.20 max	

References: American Welding Society Publication J1.3 Table 4 Notes: 1. Including Ag.

PHYSICAL AND MECHANICAL PROPERTIES FOR GROUP B (ROD & BAR)				
CLASS	UNS NUMBER	ROCKWELL HARDNESS ¹ MIN.	ELECTRICAL CONDUCTIVITY ¹ %IACS [Ms/M] MIN.	ULTIMATE COMPRESSIVE STRENGTH ¹ ksi [Mpa]
CLASS 10	N/A ²	70 HRB	45% [26]	135 [930]
CLASS 11	ASTM B702 C 1D	94 HRB	40% [23]	160 [1103]
CLASS 12	ASTM B702 C 1E	98 HRB	38% [22]	170 [1172]
CLASS 13	N/A ²	69 HRA	30% [17.4]	200 [1379]
CLASS 14	ASTM B387 TYPE 360	85 HRB	30% [17.4]	88 [607]

Reference: American Welding Society Publication J1.3 Table 6 Notes: 1. For information only. 2. Not Assigned. Note: The conductivity and hardness noted may differ from ASTM standards.

CHEMICAL COMPOSITION OF RWMA MATERIALS				
GROUP B REFRACTORY METAL AND REFRACTORY METAL COMPOSITES				
CLASS	UNS NUMBER	DESCRIPTION	CU1	W
10	NA ¹	COPPER TUNGSTEN	43-47	BAL.
11	ASTM B702 C 1D	COPPER TUNGSTEN	23-27	BAL.
12	ASTM B702 C 1 E	COPPER TUNGSTEN	18-22	BAL.
13	NA ²	TUNGSTEN		99.9 MIN.
14	ASTM B287 ALLOY 360 OR 361	MOLYBDENUM		(MO) 99.9 MIN

References: American Welding Society Publication J1.3 & ASTM Table 4 Notes: 1. Not assigned 2. Not assigned.

MATERIAL COMPATIBILITY



MATERIAL COMPATIBILITY of Similar Ferrous Metals	
WORKPIECE MATERIAL	RECOMMENDED ELECTRODE CLASS
Chrome Plate	2
Cold-Rolled Steel	2
Galvanized Steel	1, 2, 20
Stainless Steel	2, 3
Terne Plate	1, 2, 20
Tin Plate	1, 2, 20

MATERIAL COMPATIBILITY of Similar Non-Ferrous Metals	
WORKPIECE MATERIAL	RECOMMENDED ELECTRODE CLASS
Aluminum and Aluminum Alloys	1, 2
Bronze	2
Copper	13, 14
Cupronickel	2
Magnesium	2
Nickel and Nickel Alloys	2
Nickel - Silver	2
Phosphor Bronze	2
Red Brass	2
Silicon	13, 14
Titanium	1, 2
Yellow Brass	2

MATERIAL COMPATIBILITY of Refractory Metals	
WORKPIECE MATERIAL	RECOMMENDED ELECTRODE CLASS
Tungsten	2
Molybdenum	2

References: American Welding Society Publication J1.3 & ASTM Table 3. Note: The same electrode alloy should be used on both sides for all materials listed.

RESISTANCE WELDING PRODUCTS

Cadi has the expertise, equipment, and material to make your most complicated parts. From one piece to 10,000 pieces, let Cadi be your source for resistance welding products.

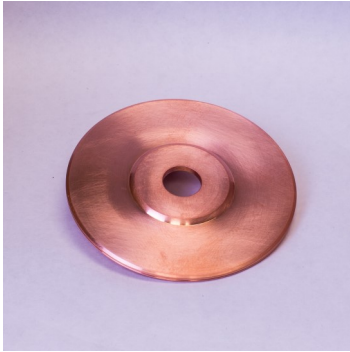

SEAM WELD WHEEL



RESISTANCE WELDING PARTS



CYLINDER ACCESSORIES



CUSTOM ELECTRODES

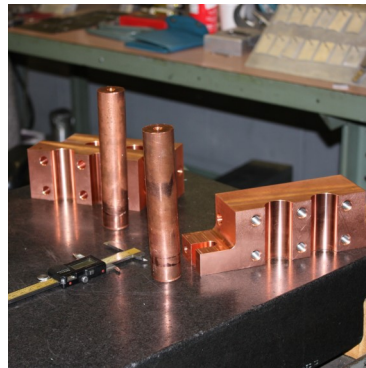

QUALITY CONTROL



SWIVEL HEAD ELECTRODES

Visit us at Fabtech!



The trade show booth is divided into two main sections. The left section, titled 'High Conductivity Copper Alloys', features a large photograph of a warehouse aisle with high ceilings and industrial shelving. To the left of the photo are three red vertical banners listing RWMA Class 1 (C15000), Class 2 (C18150, C18200), and Class 3 (C18000, C17310). The right section, titled 'Resistance Welding Products', features a collage of copper products including rods, pins, and electrodes. To the right of the collage is a vertical list of welding processes: Seam Welding, Wire Welding, Spot Welding, and Projection Welding. At the bottom right of this section are social media icons for Facebook, Twitter, and LinkedIn. The Cadi Company Inc. logo and tagline 'Your Direct Source for Copper, Alloy Bar Stock and Machined Products' are positioned at the top center of the booth.

RESISTANCE WELDING PRODUCTS

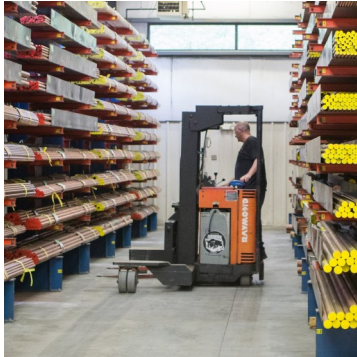

BAR STOCK



FINISHED SEAM WHELD WHEEL



SINGLE BEND ELECTRODE

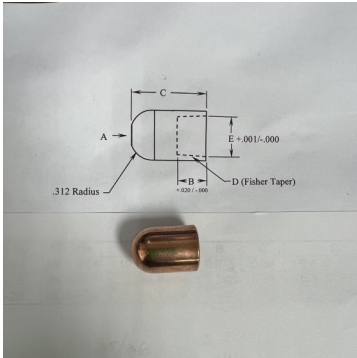

DOME CAP



RESISITANCE WELDING PARTS



LONG DOME CAPS



MESH WELDING DIES



SEAM WELD WHEEL BLANKS



HOLDER



ROUND BILLET

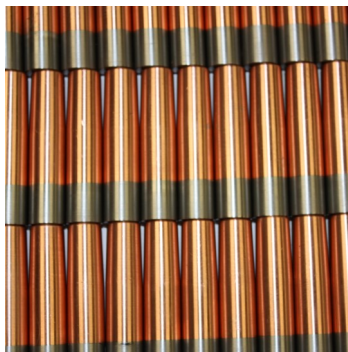

REFRACTORY FACED ELECTRODE



DOUBLE BEND ELECTRODE

Cadi Company, Inc. P.O. Box 1127, 60 Rado Drive, Naugatuck, CT 06770
www.cadicompany.com 800-243-3650 203-729-1111





Cadi Company Inc.



Cadi Company, Inc. believes the contents of this catalog to be correct at the time of publication and shall not be held responsible for any typos or misspellings. For general terms and condition of sales refer to <https://www.cadicompany.com/cms/terms-and-conditions>.

The Cadi Company, Inc. product catalog is provided for the private use of our customers. This catalog cannot be reproduced (in part or in whole) or used for any other purpose without expressed written permission from Cadi Company, Inc. The catalog and pictures are the sole property of Cadi Company, Inc. All rights reserved.



Cadi Company, Inc. P.O. Box 1127, 60 Rado Drive, Naugatuck, CT 06770
www.cadicompany.com 800-243-3650 203-729-1111